

500 kV	Generator	Circuit breaker	Reactor	2 Winding tap transformer	2 Winding fixed tap transformer
330 kV	Wind Farm	Isolator	Series Reactor	3 Winding tap transformer	3 Winding fixed tap transformer
275 kV	Static Var Compensator	Capacitor Bank	Auto transformer		
220 kV	Synchronous Condenser				
132 / 110 kV					
66 kV					
33 kV					
22 kV					

This diagram is intended to be a high-level representation only, interested parties should always consult with their relevant transmission network service provider (or equivalent) for more accurate information.

DATE: 30-01-2015

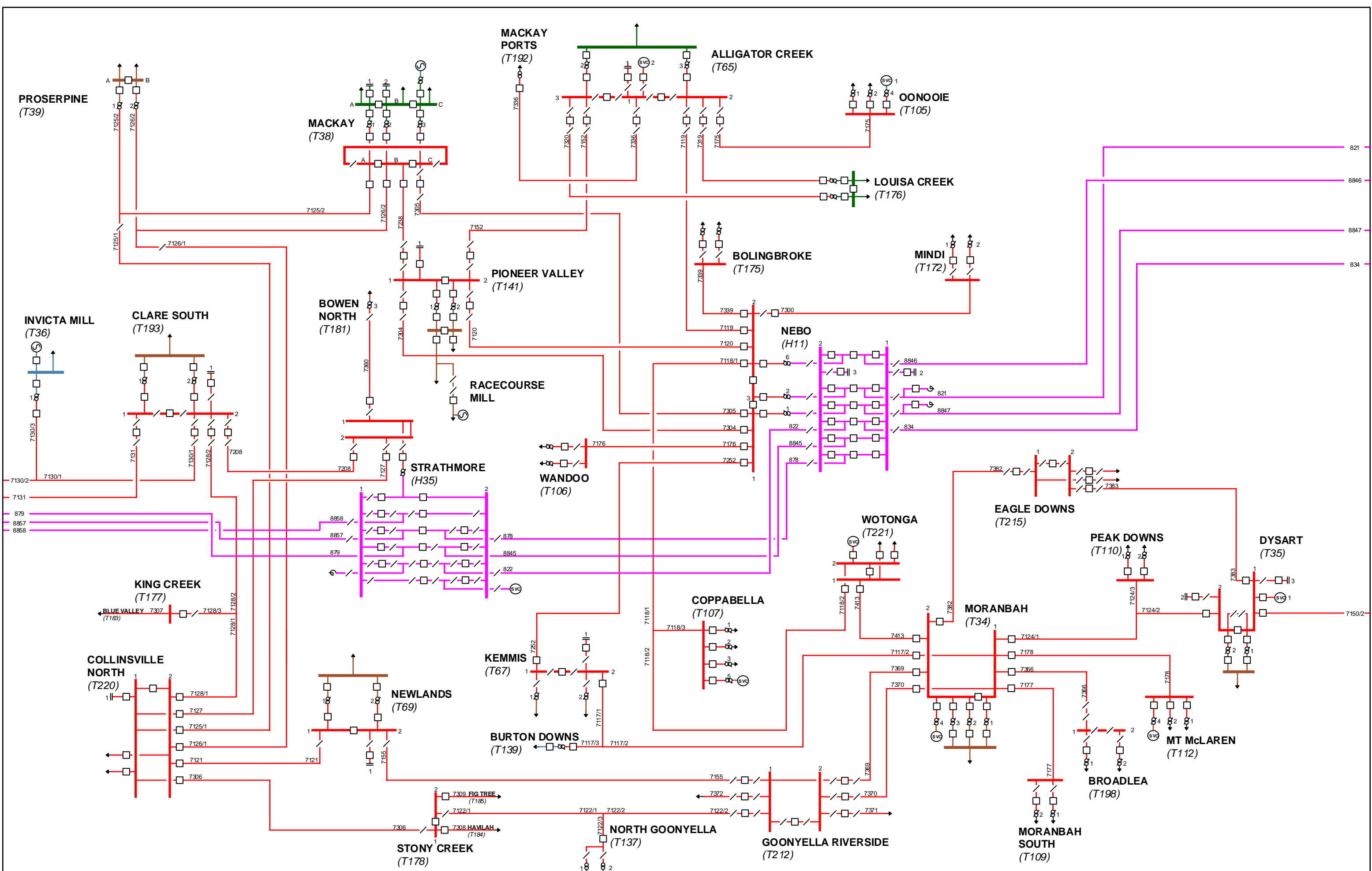

QLD - a	QLD - b	QLD - c
---------	---------	---------

500 kV	Generator	Circuit breaker	Reactor	2 Winding tap transformer	2 Winding fixed tap transformer
330 kV	Wind Farm	Isolator	Series Reactor	3 Winding tap transformer	3 Winding fixed tap transformer
275 kV	Static Var Compensator	Capacitor Bank	Auto transformer		
220 kV	Synchronous Condenser				
132 / 110 kV					
66 kV					
33 kV					
22 kV					

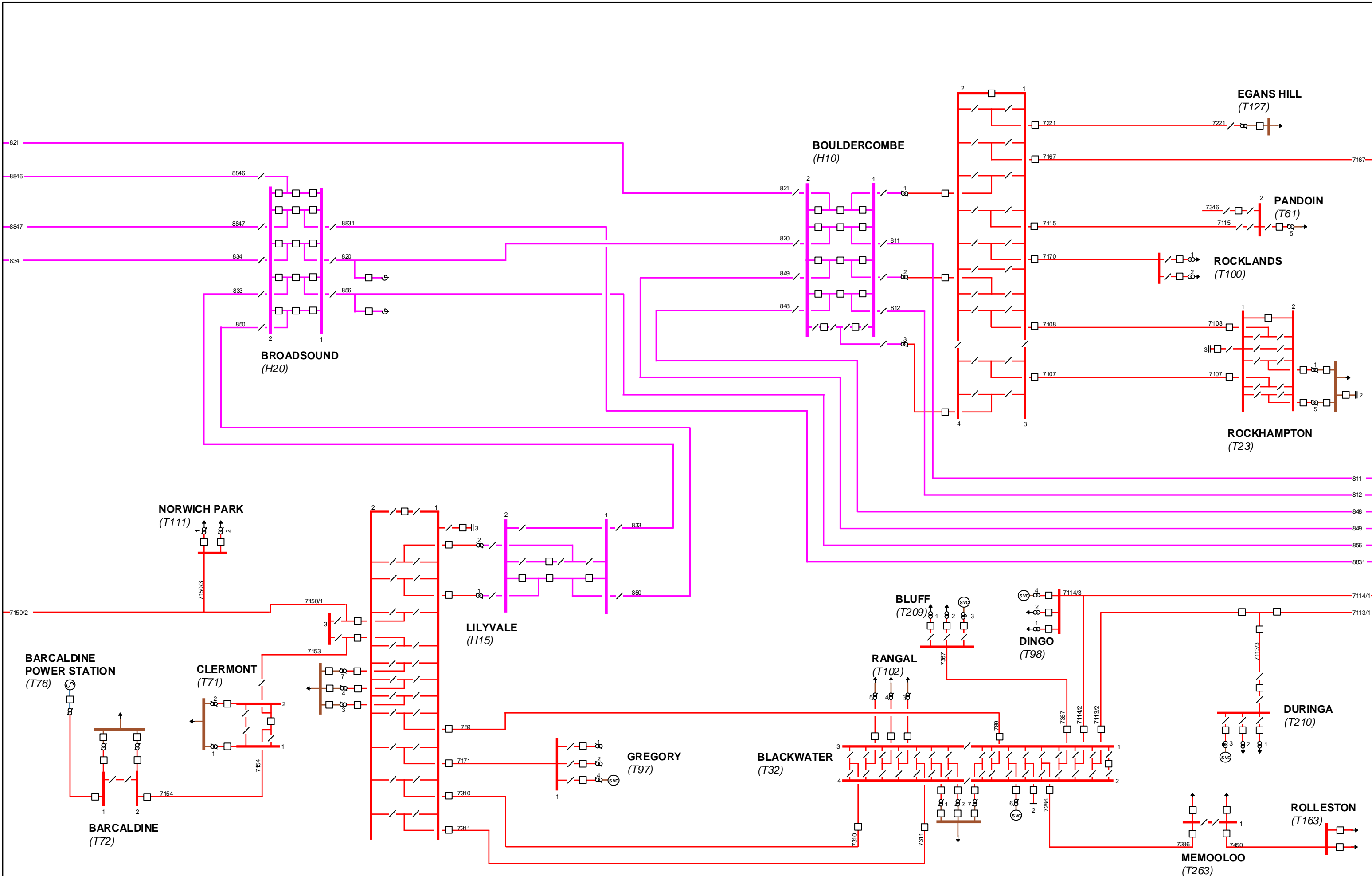

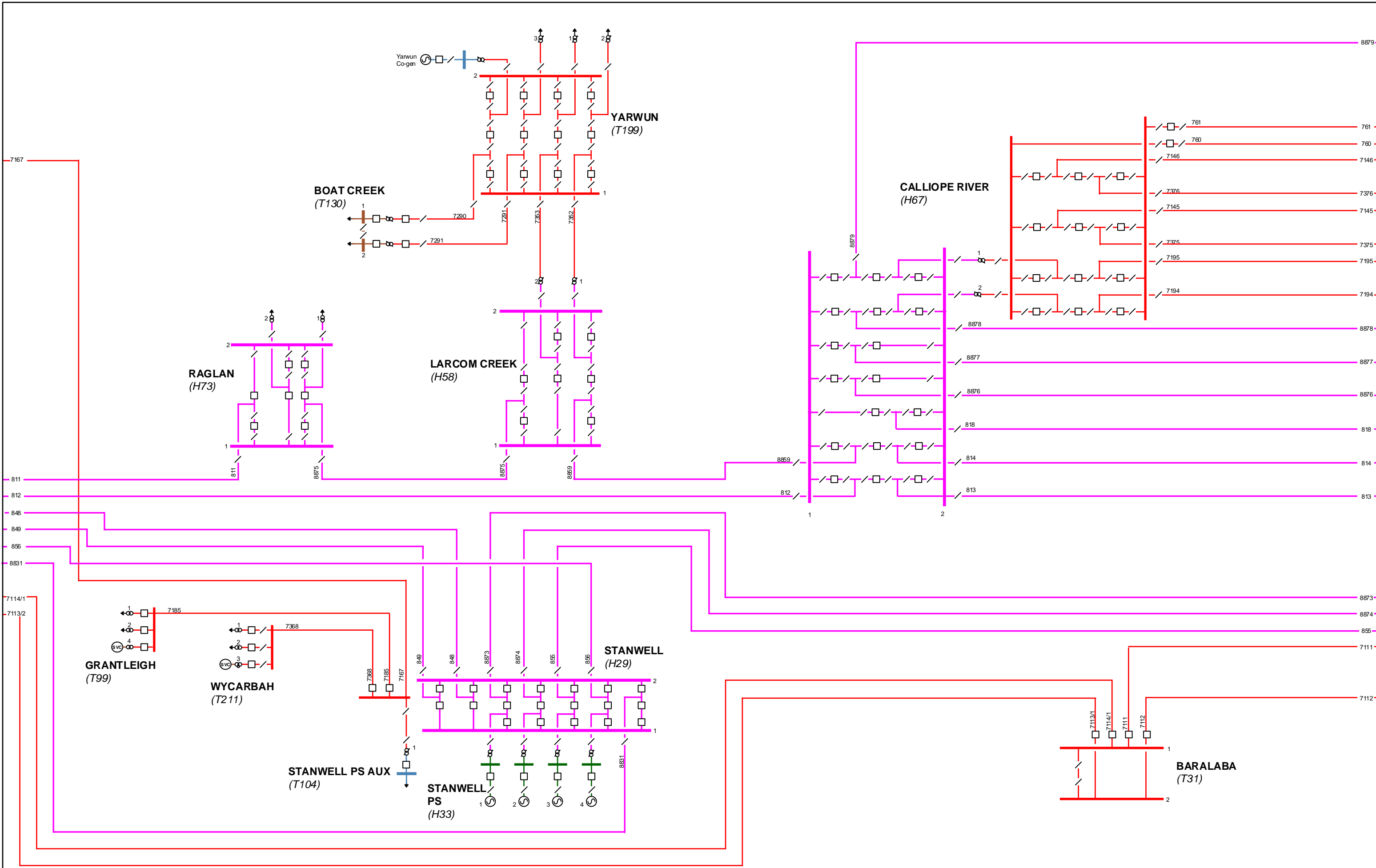

QLD - c	QLD - d	QLD - e
---------	---------	---------

- 500 kV
- 330 kV
- 275 kV
- 220 kV
- 132 / 110 kV
- 66 kV
- 33 kV
- 22 kV

- Generator
- Wind Farm
- Static Var Compensator
- Synchronous Condenser
- Circuit breaker
- Isolator
- Capacitor Bank
- Reactor
- Series Reactor
- 2 Winding tap transformer
- 3 Winding tap transformer
- Auto transformer
- 2 Winding fixed tap transformer
- 3 Winding fixed tap transformer

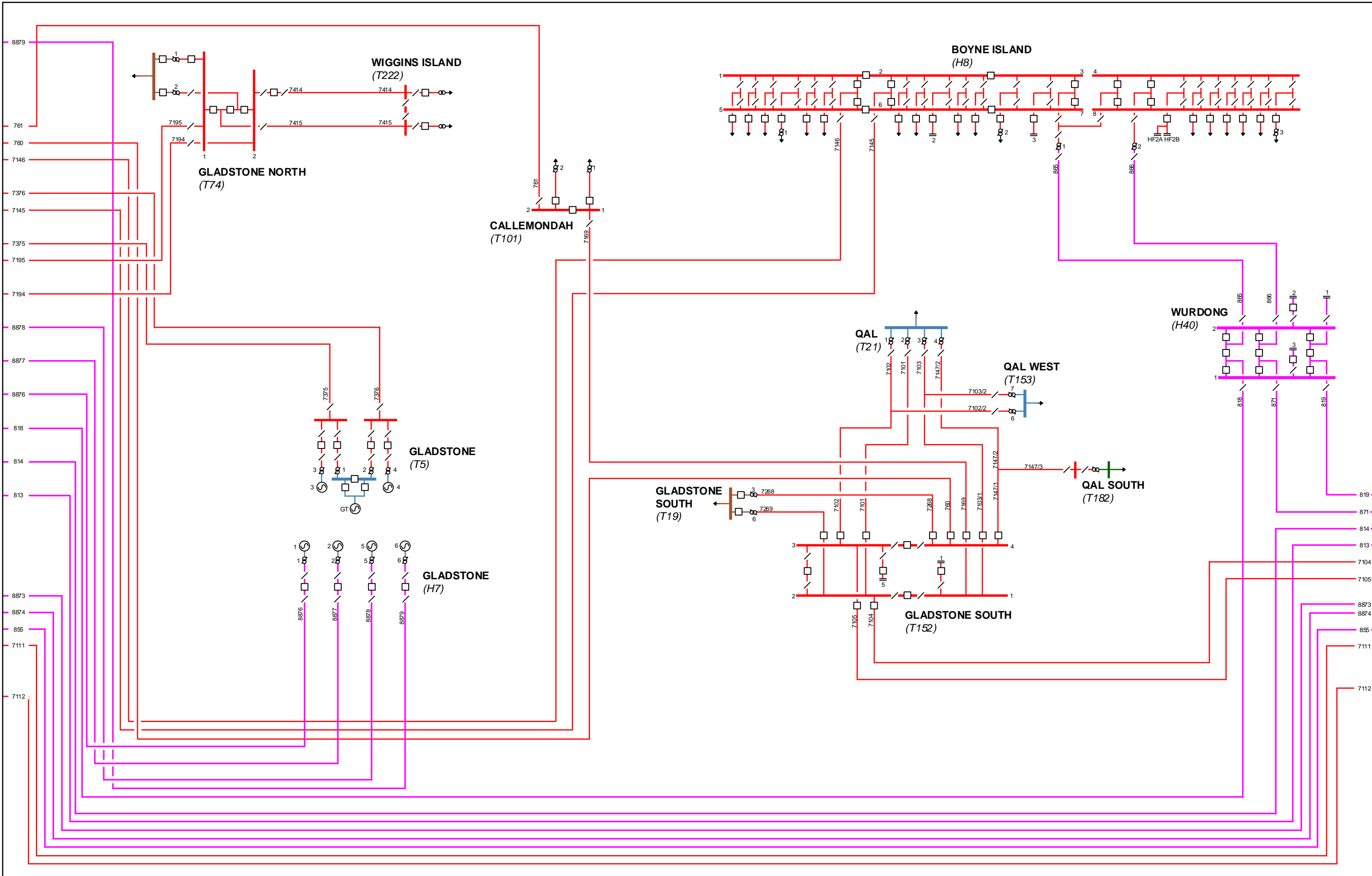

QLD - d	QLD - e	QLD - f
---------	---------	---------

- 500 kV
- 330 kV
- 275 kV
- 220 kV
- 132 / 110 kV
- 66 kV
- 33 kV
- 22 kV

- Generator
- Wind Farm
- Static Var Compensator
- Synchronous Condensor
- Circuit breaker
- Isolator
- Capacitor Bank
- Reactor
- Series Reactor
- 2 Winding tap transformer
- 3 Winding tap transformer
- Auto transformer
- 2 Winding fixed tap transformer
- 3 Winding fixed tap transformer

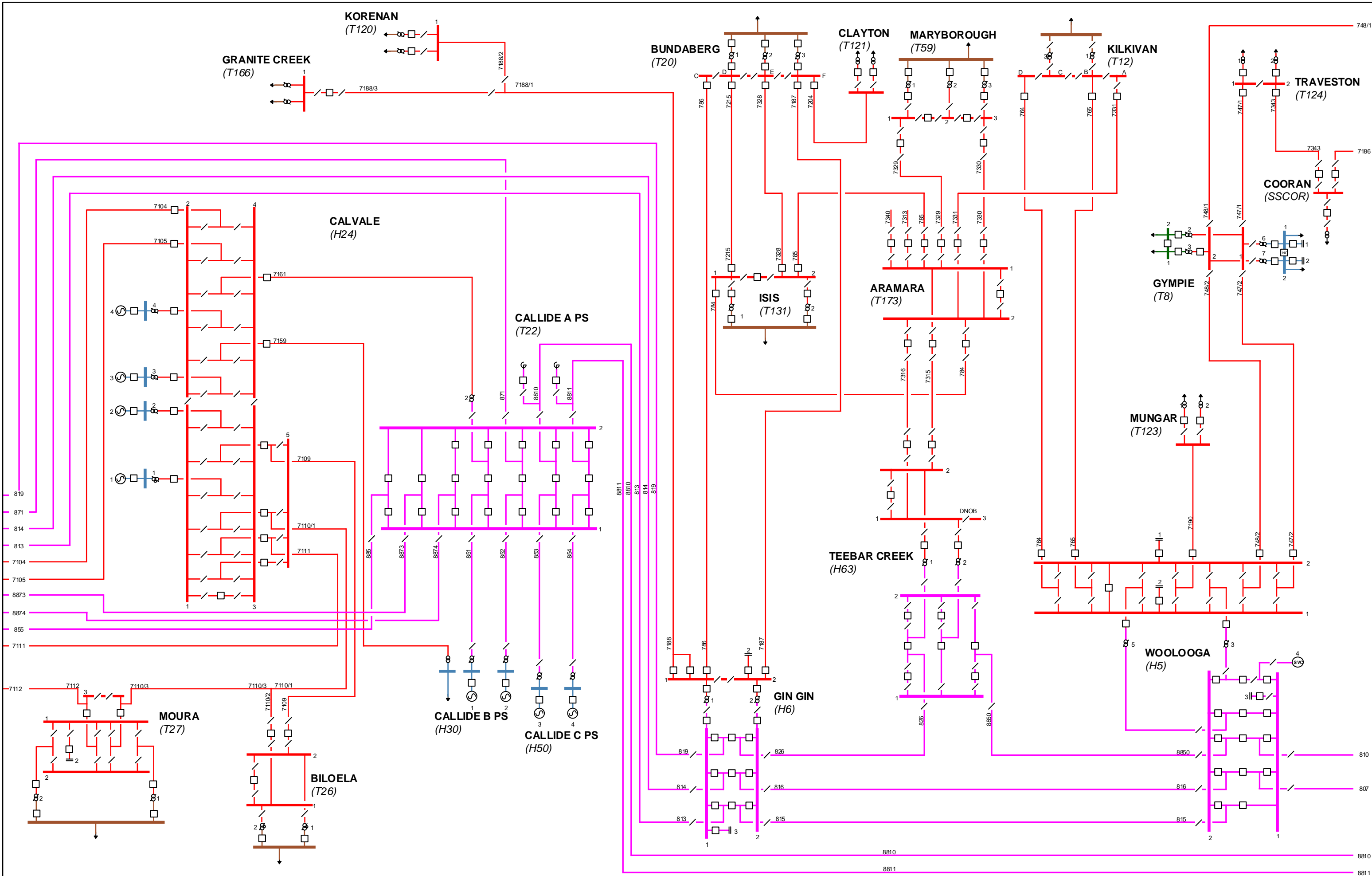

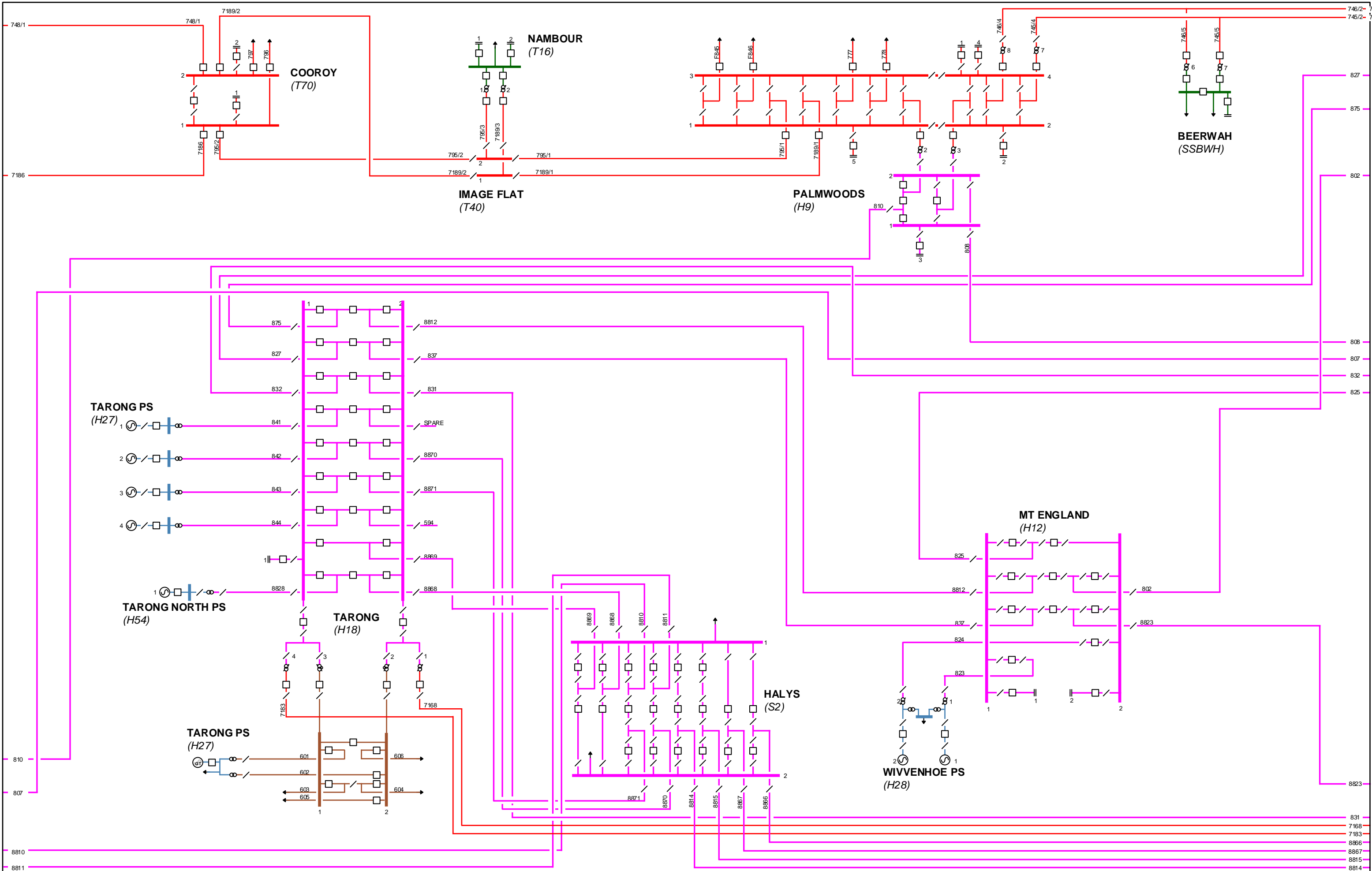

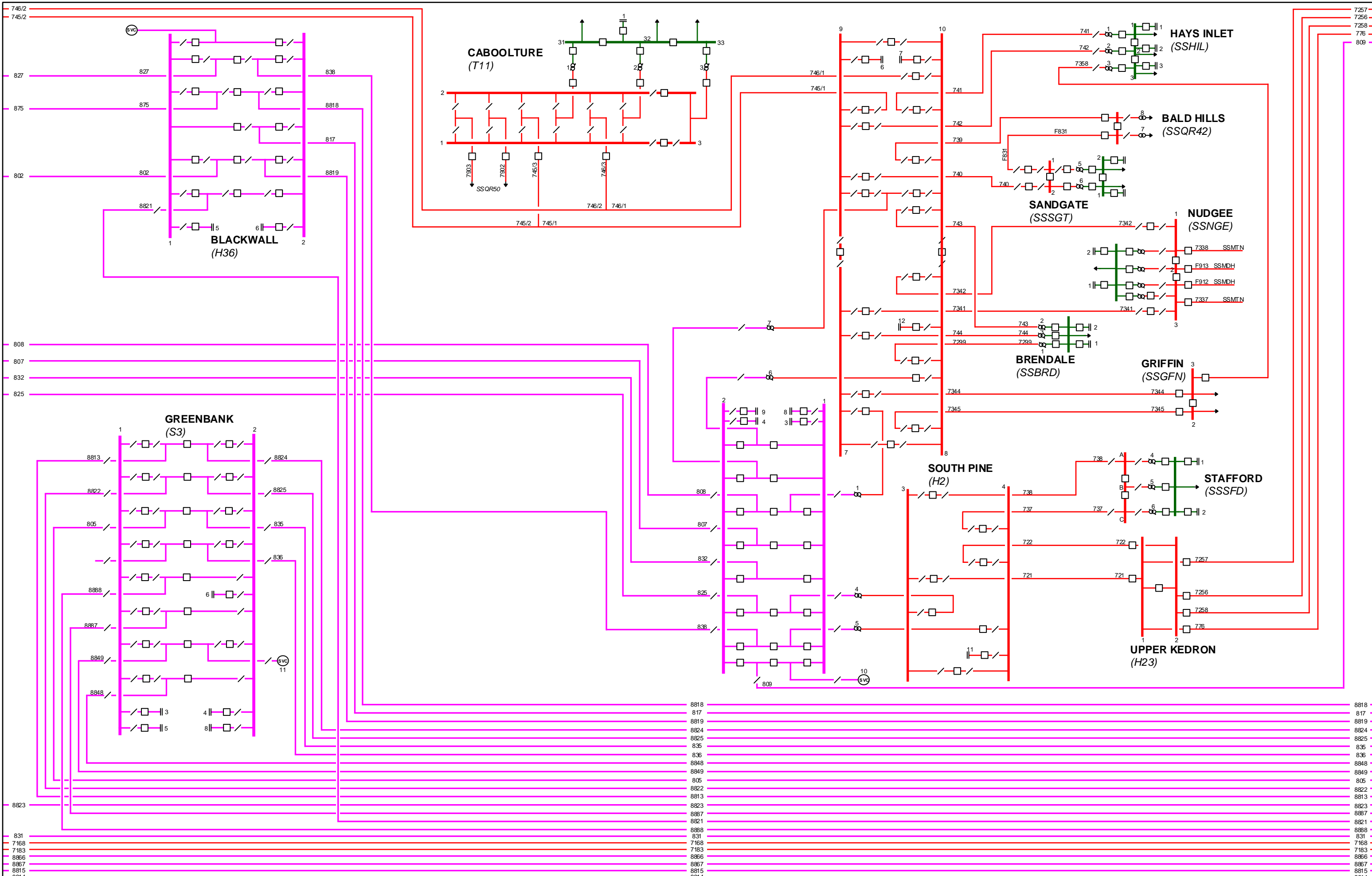



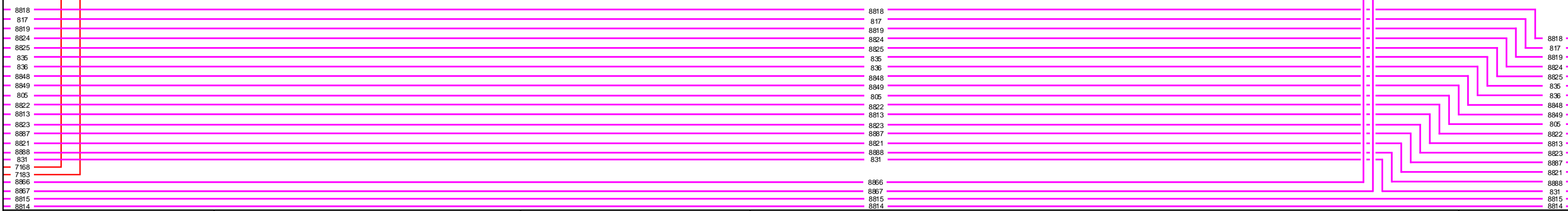
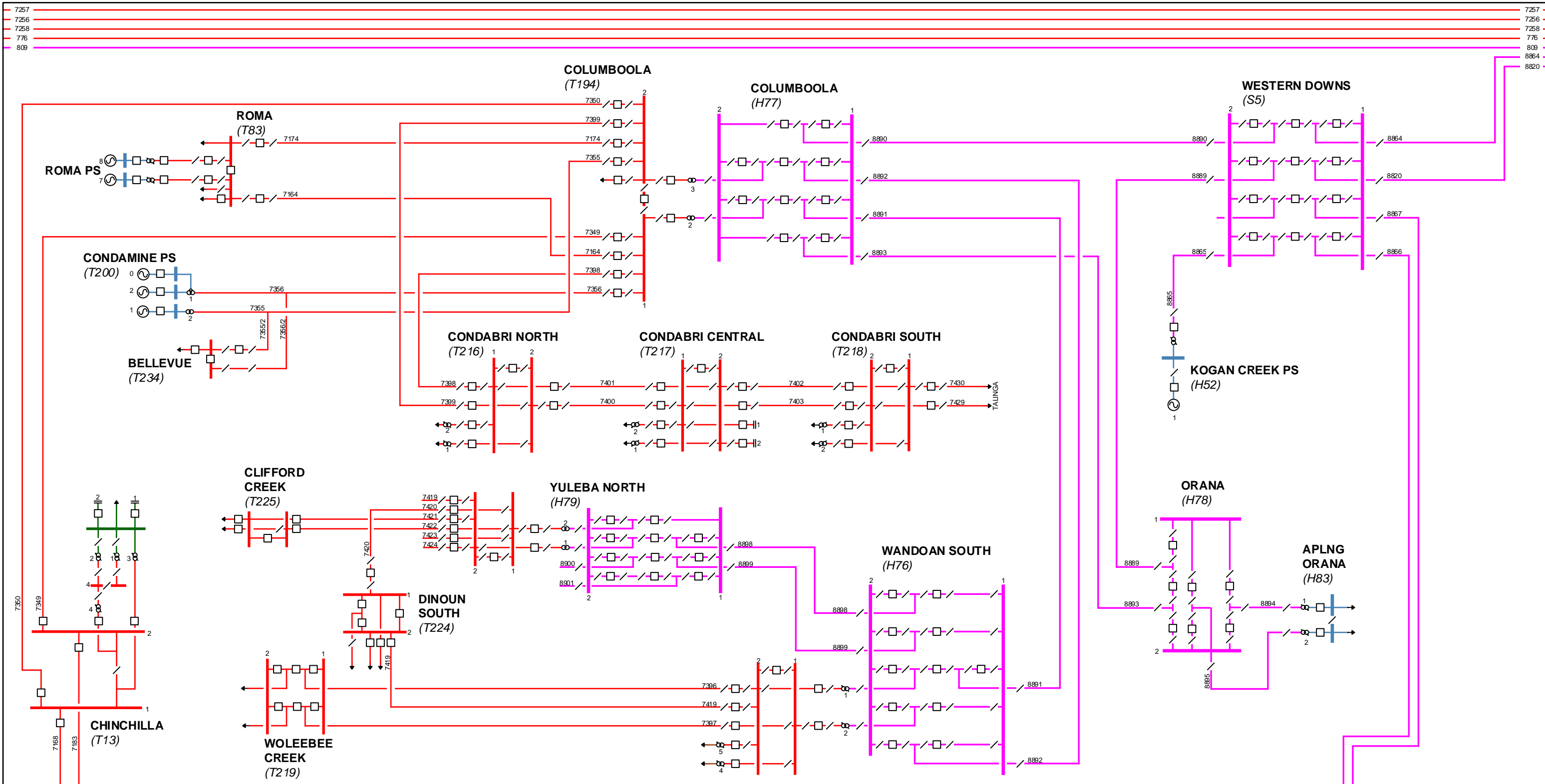

AUSTRALIAN ENERGY MARKET OPERATOR  
HIGH VOLTAGE NETWORK  
MAIN SYSTEM DIAGRAM  
QUEENSLAND - i

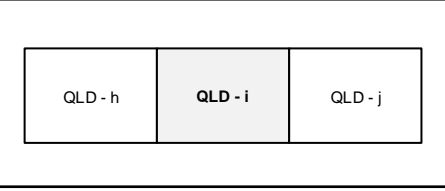

<ul style="list-style-type: none"> <li>500 kV</li> <li>330 kV</li> <li>275 kV</li> <li>220 kV</li> <li>132 / 110 kV</li> <li>66 kV</li> <li>33 kV</li> <li>22 kV</li> </ul>	<ul style="list-style-type: none"> <li>Generator</li> <li>Wind Farm</li> <li>Static Var Compensator</li> <li>Synchronous Condenser</li> </ul>	<ul style="list-style-type: none"> <li>Circuit breaker</li> <li>Isolator</li> <li>Capacitor Bank</li> </ul>	<ul style="list-style-type: none"> <li>Reactor</li> <li>Series Reactor</li> </ul>	<ul style="list-style-type: none"> <li>2 Winding tap transformer</li> <li>3 Winding tap transformer</li> <li>Auto transformer</li> </ul>	<ul style="list-style-type: none"> <li>2 Winding fixed tap transformer</li> <li>3 Winding fixed tap transformer</li> </ul>
---	---	---	---	--	--

This diagram is intended to be a high-level representation only, interested parties should always consult with their relevant transmission network service provider (or equivalent) for more accurate information.

DATE: 30-01-2015

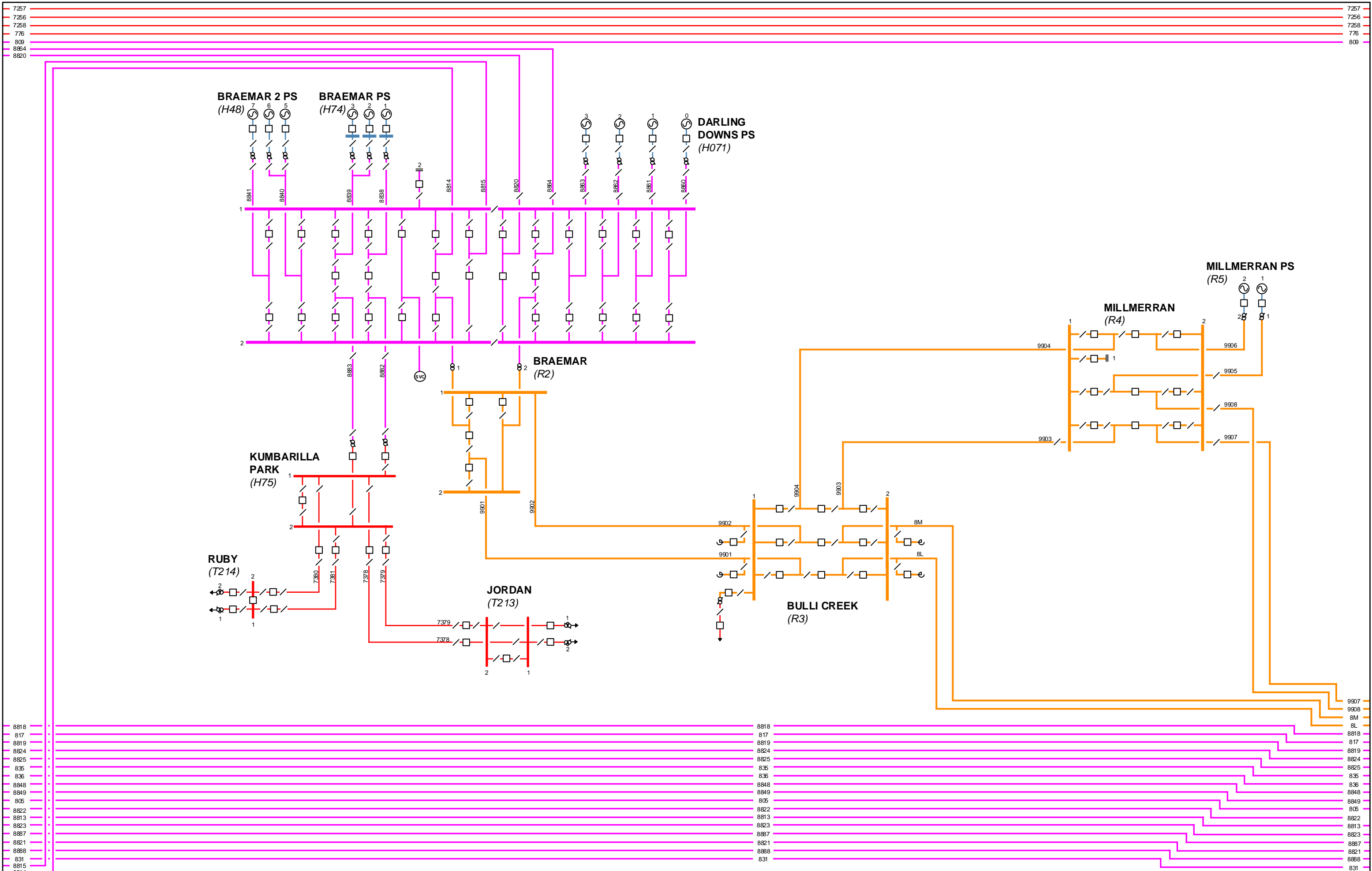

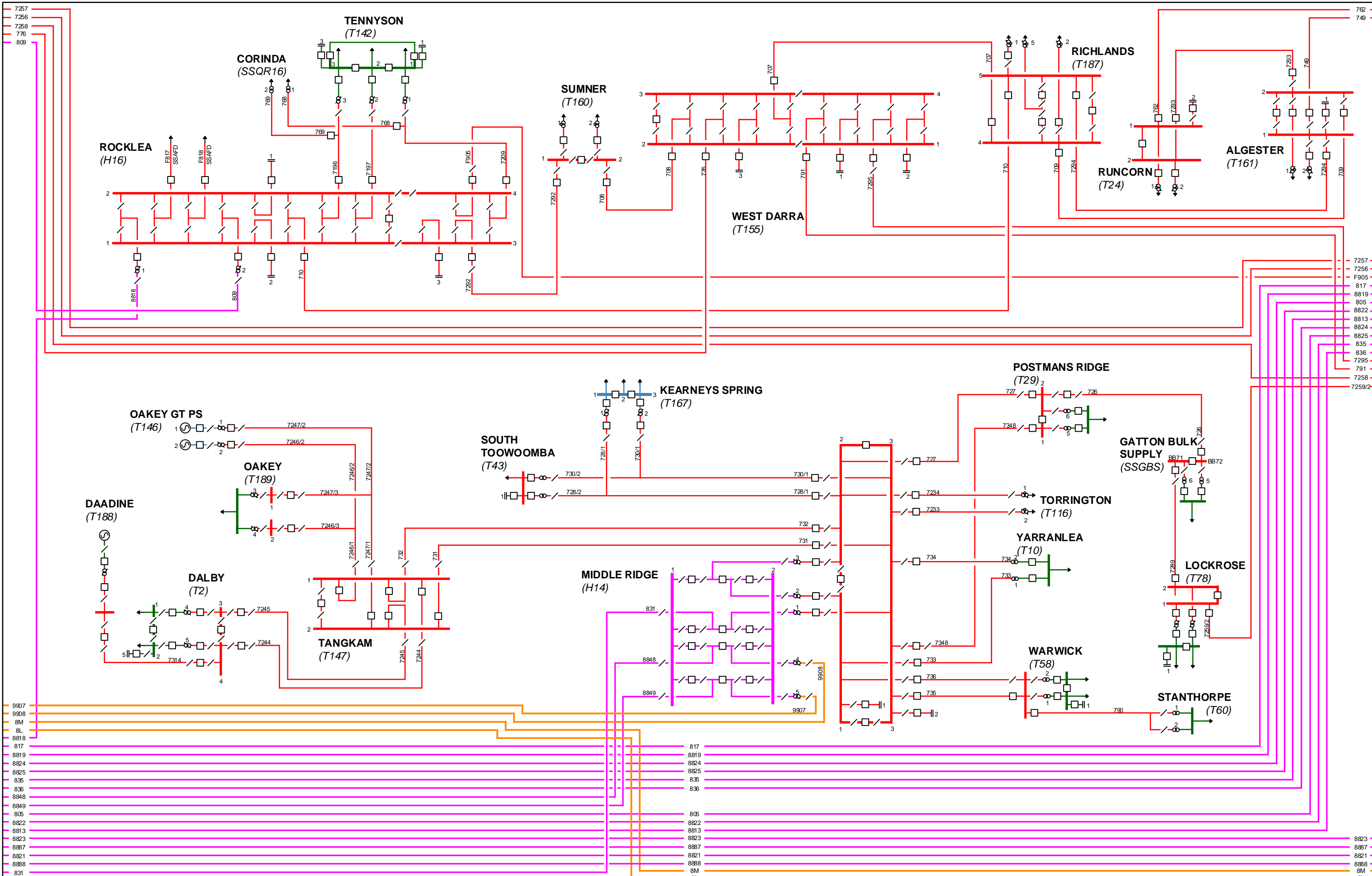

9907	817	817	500 kV	Generator	Circuit breaker	Reactor	2 Winding tap transformer	2 Winding fixed tap transformer
9908	819	819	330 kV	Wind Farm	Isolator	Series Reactor	3 Winding tap transformer	3 Winding fixed tap transformer
8M	824	824	275 kV	Static Var Compensator	Capacitor Bank	Auto transformer		
8L	825	825	220 kV	Synchronous Condenser				
8818	835	835	132 / 110 kV					
817	836	836	66 kV					
8819	848	848	33 kV					
8824	887	887	22 kV					
8825	888	888						
835	821	821						
836	888	888						
8848	8M	8M						
8849	81	81						
805								
8822								
8813								
8823								
8887								
8821								
8888								
831								



AUSTRALIAN ENERGY MARKET OPERATOR  
 HIGH VOLTAGE NETWORK  
 MAIN SYSTEM DIAGRAM  
 QUEENSLAND - k

QLD - j	QLD - k	QLD - l
---------	---------	---------

This diagram is intended to be a high-level representation only, interested parties should always consult with their relevant transmission network service provider (or equivalent) for more accurate information.

DATE: 30-01-2015

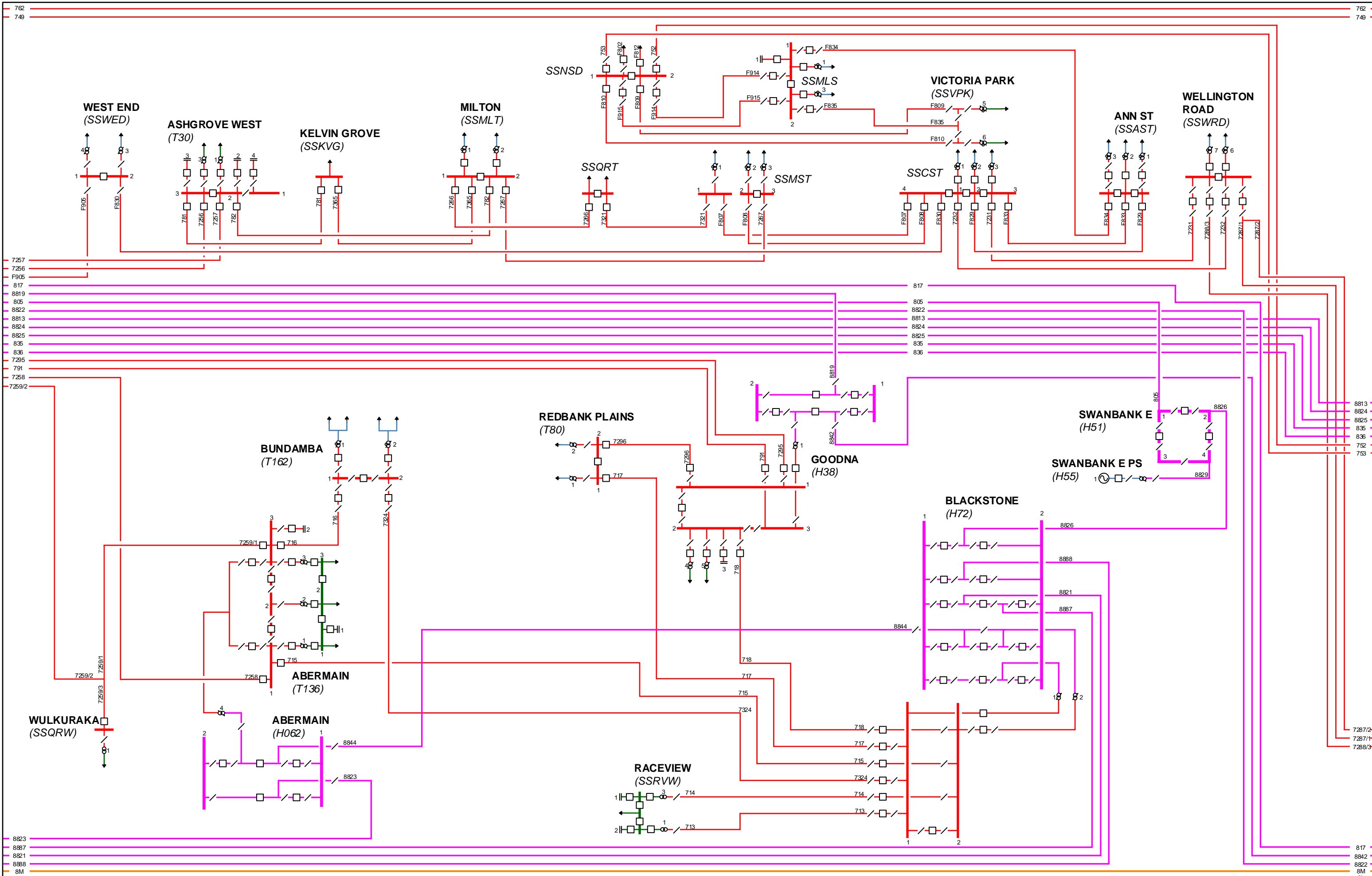

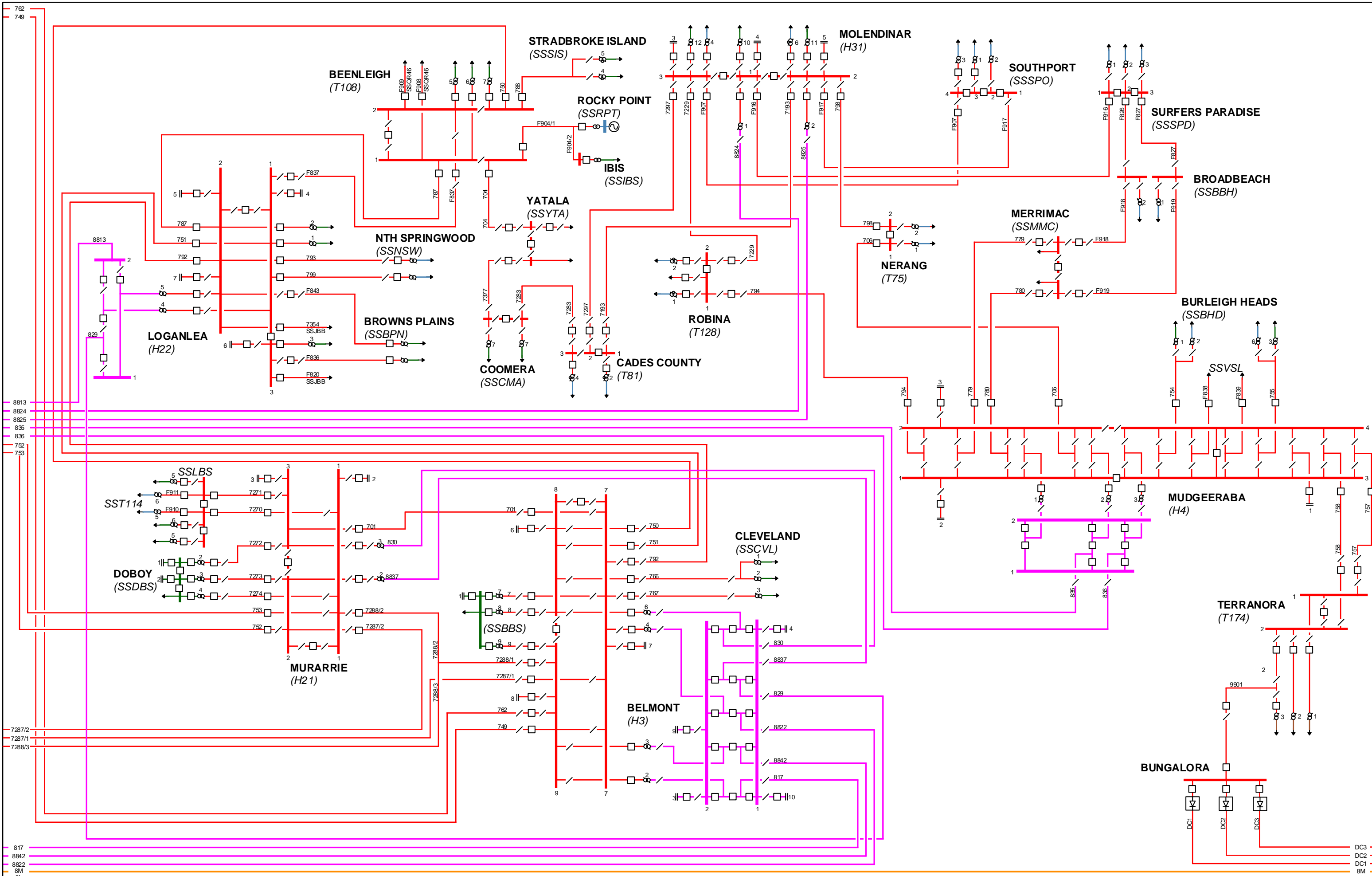

762  
749  
8813  
8824  
8825  
835  
836  
752  
753  
7287/2  
7287/1  
7288/3  
817  
8842  
8822  
8M  
8L

DC3  
DC2  
DC1  
8M  
8L



AUSTRALIAN ENERGY MARKET OPERATOR  
HIGH VOLTAGE NETWORK  
MAIN SYSTEM DIAGRAM  
QUEENSLAND - m

QLD - l	QLD - m	NSW - a
---------	---------	---------

- 500 kV
- 330 kV
- 275 kV
- 220 kV
- 132 / 110 kV
- 66 kV
- 33 kV
- 22 kV

- Generator
- Wind Farm
- Static Var Compensator
- Synchronous Condenser
- Circuit breaker
- Isolator
- Capacitor Bank
- Reactor
- Series Reactor
- 2 Winding tap transformer
- 3 Winding tap transformer
- Auto transformer
- 2 Winding fixed tap transformer
- 3 Winding fixed tap transformer

This diagram is intended to be a high-level representation only, interested parties should always consult with their relevant transmission network service provider (or equivalent) for more accurate information.

DATE: 30-01-2015

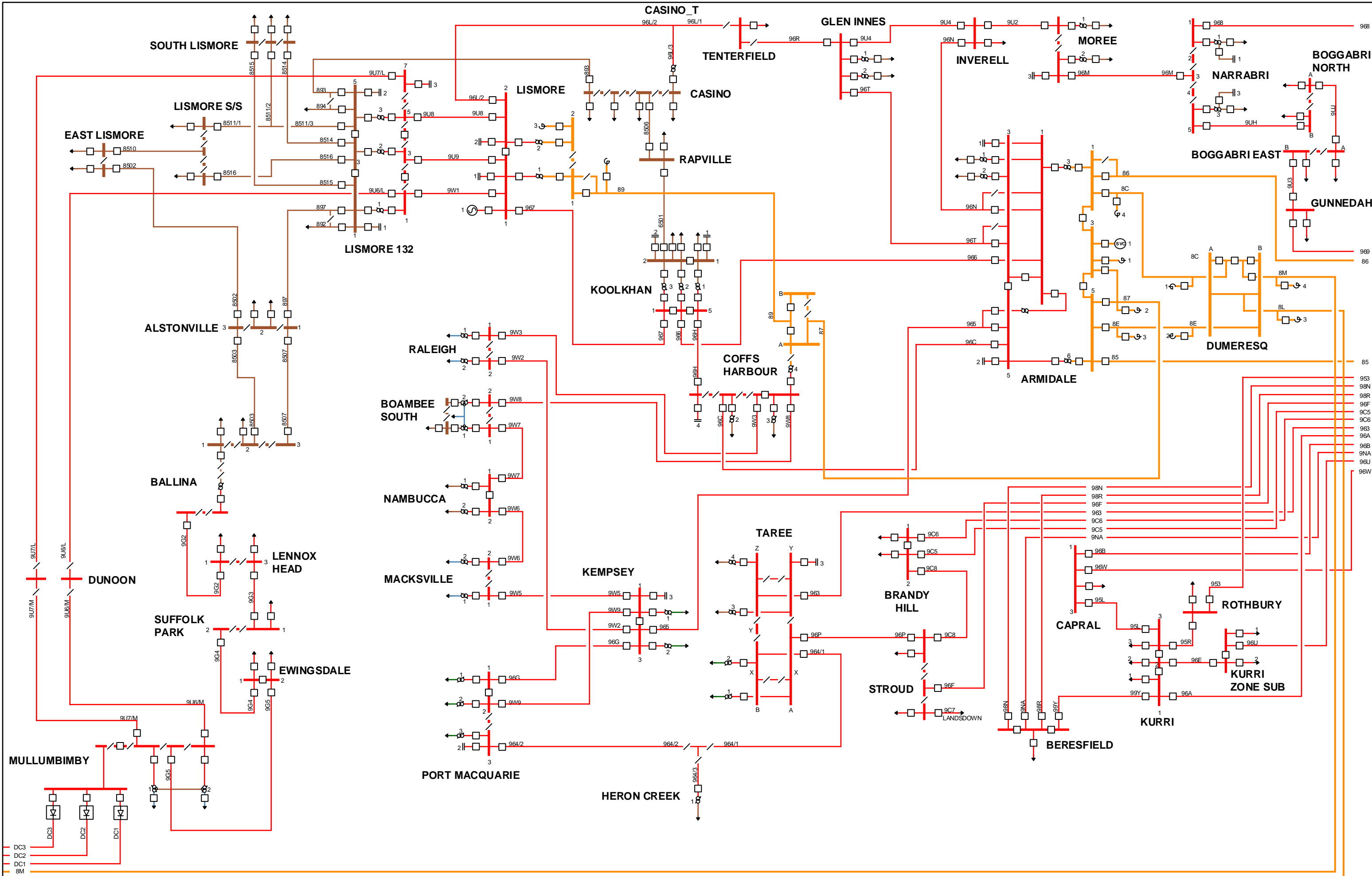

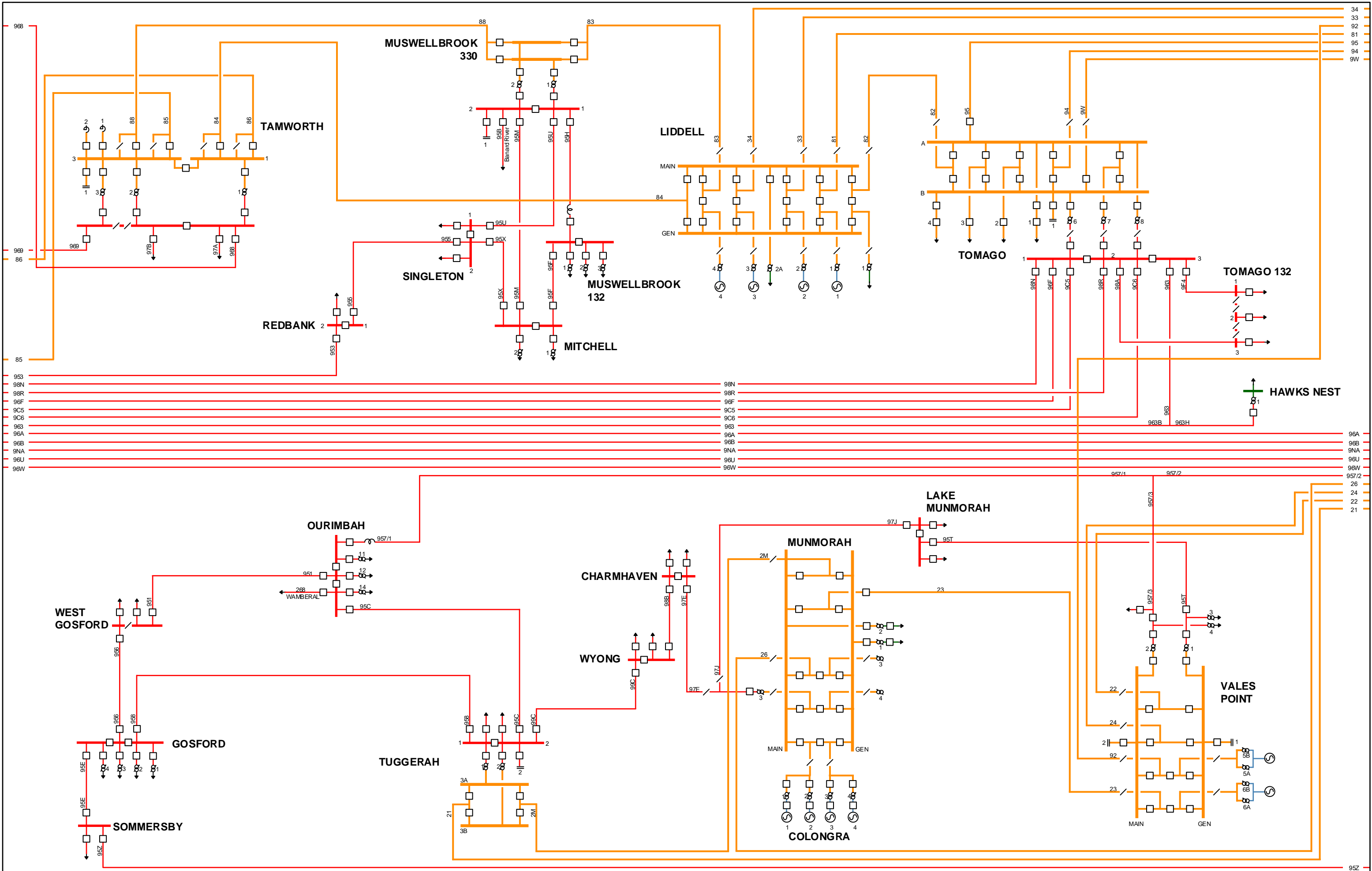



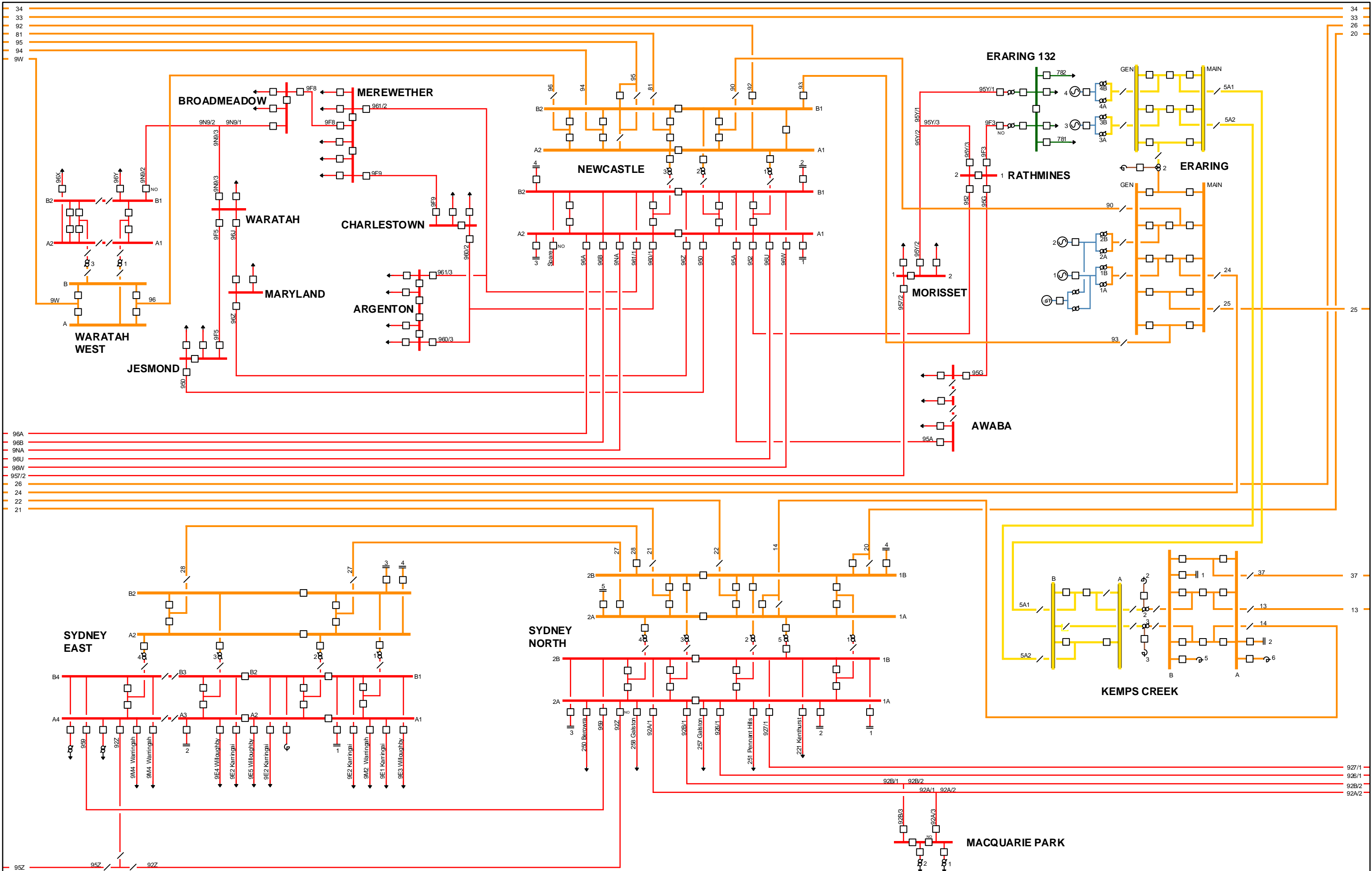



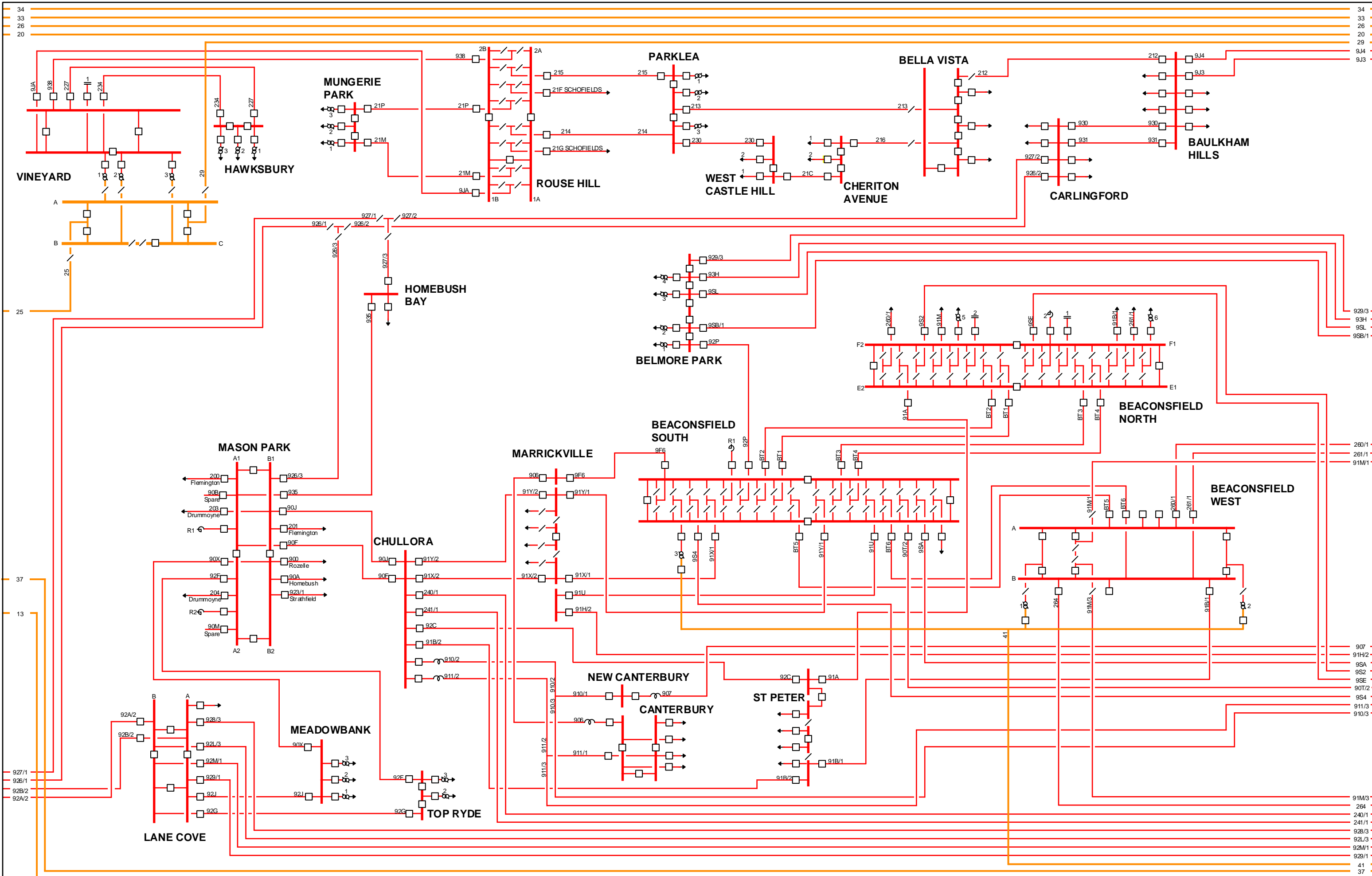

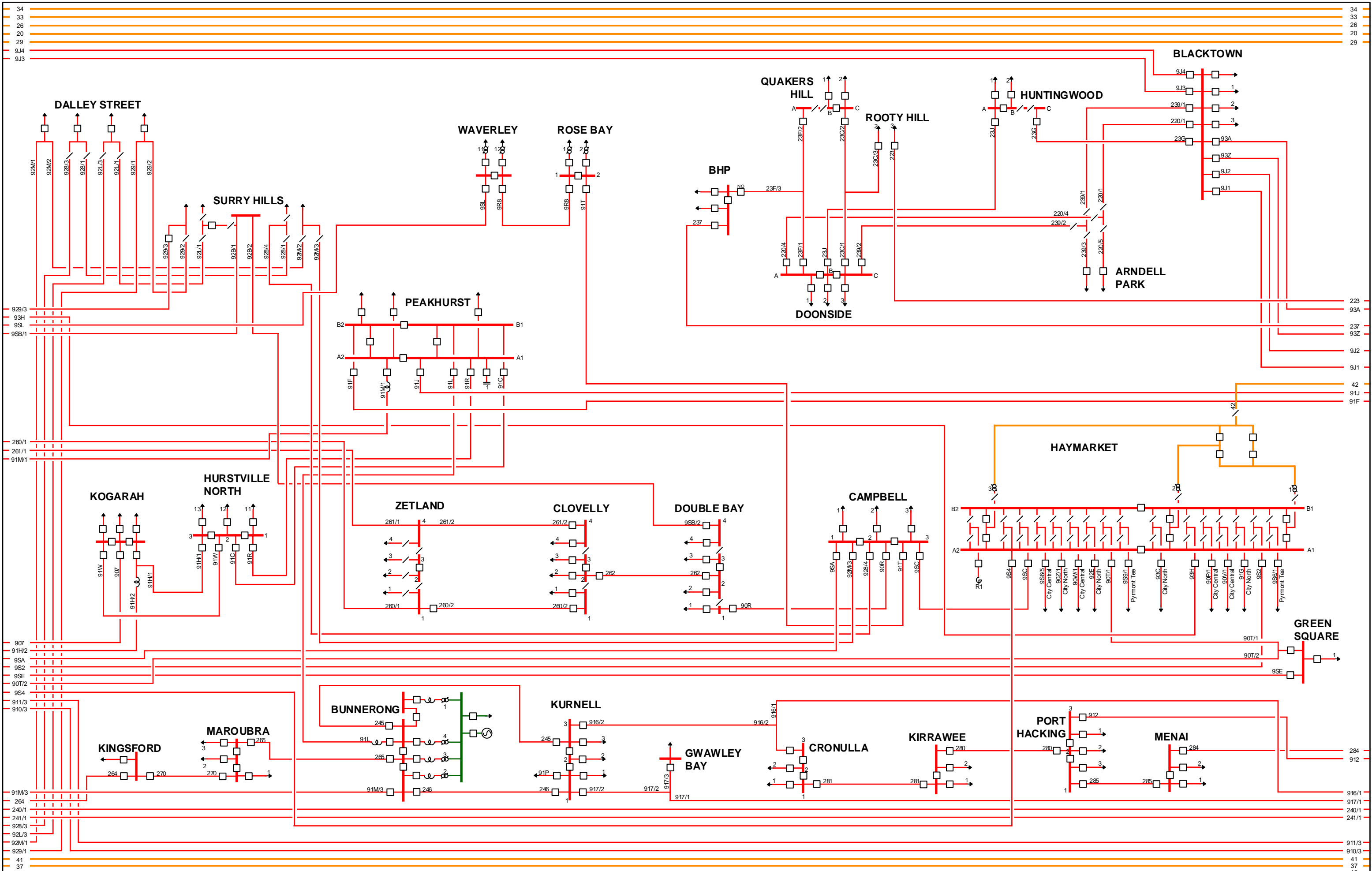

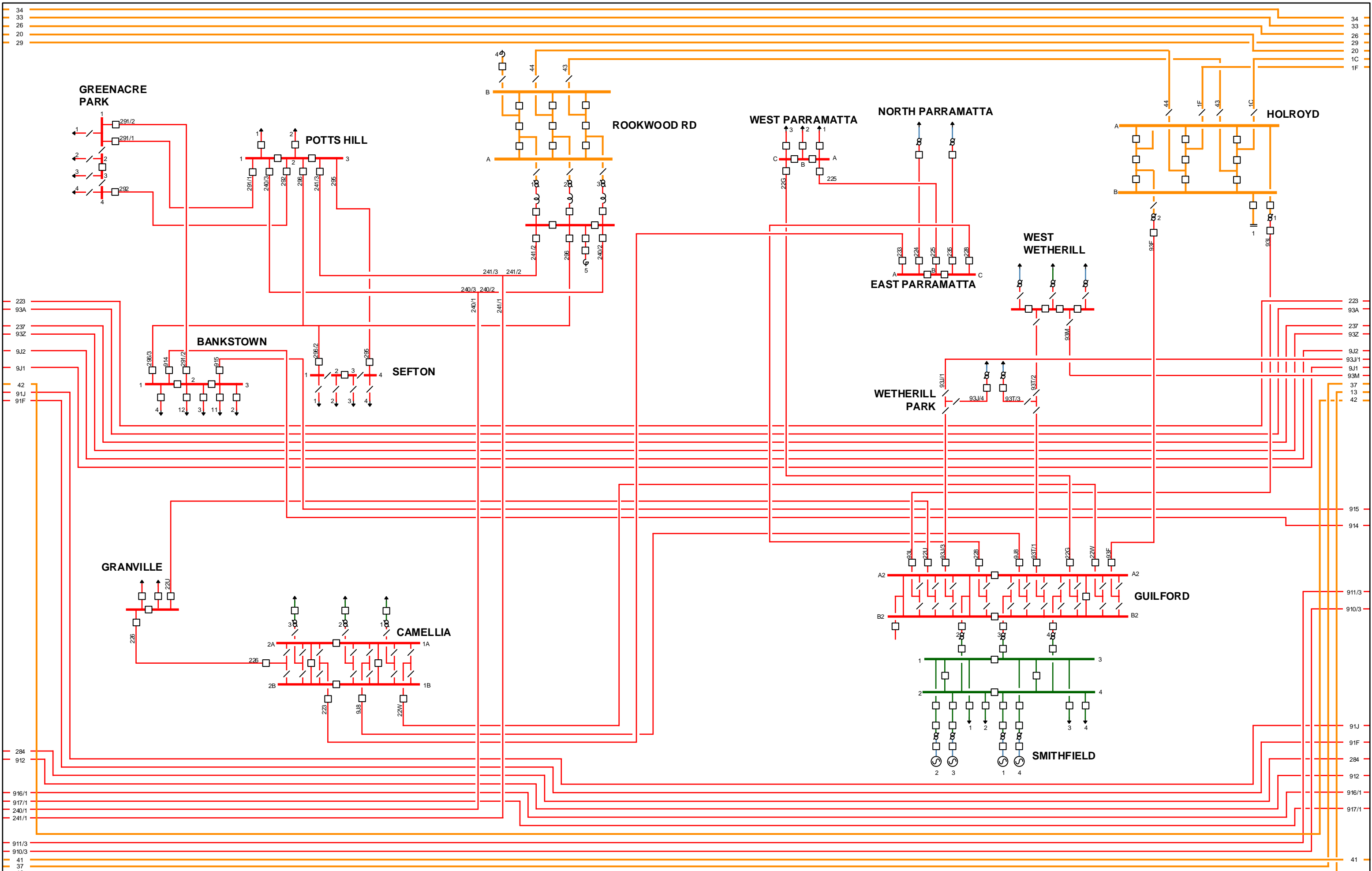

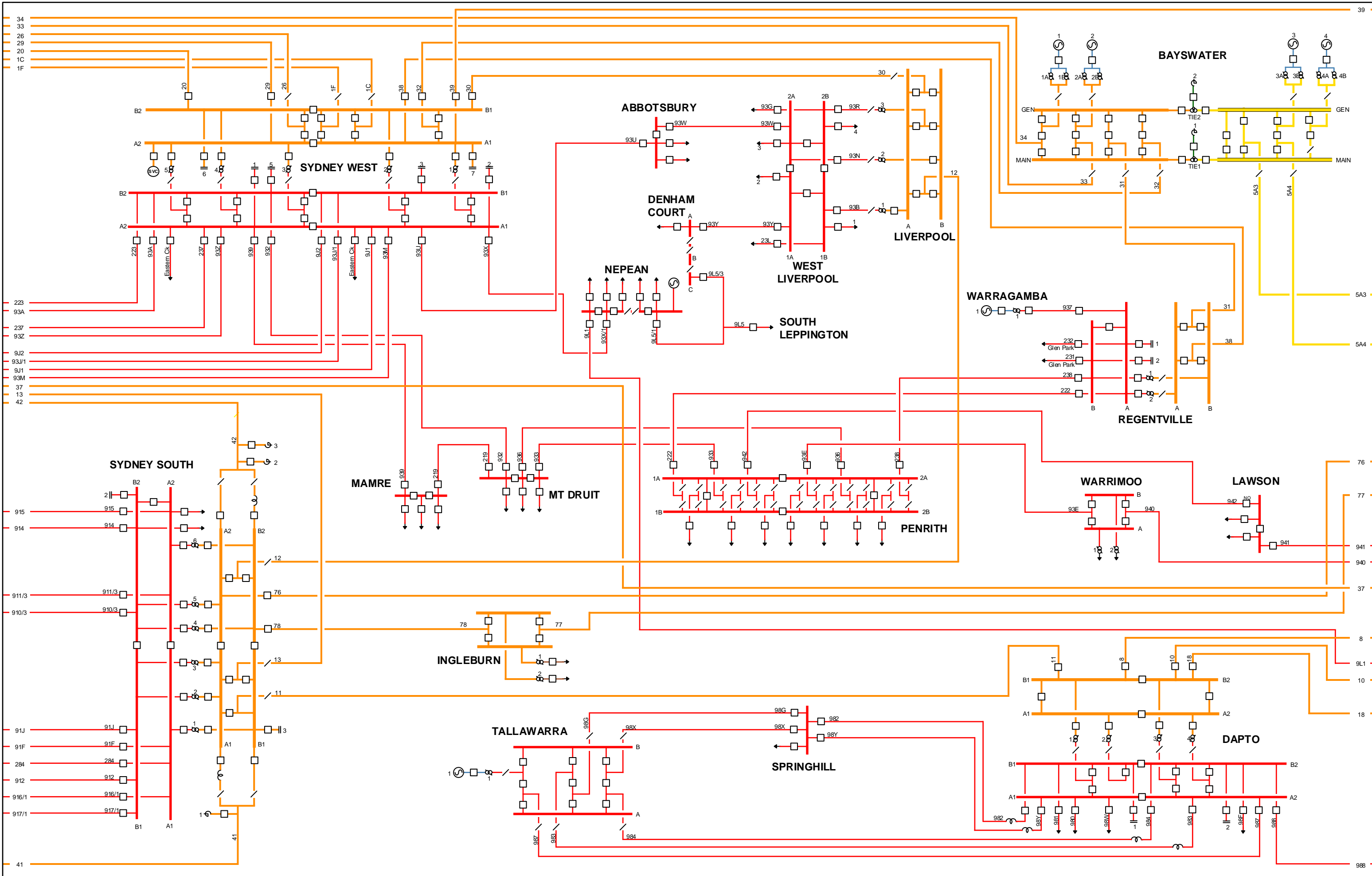



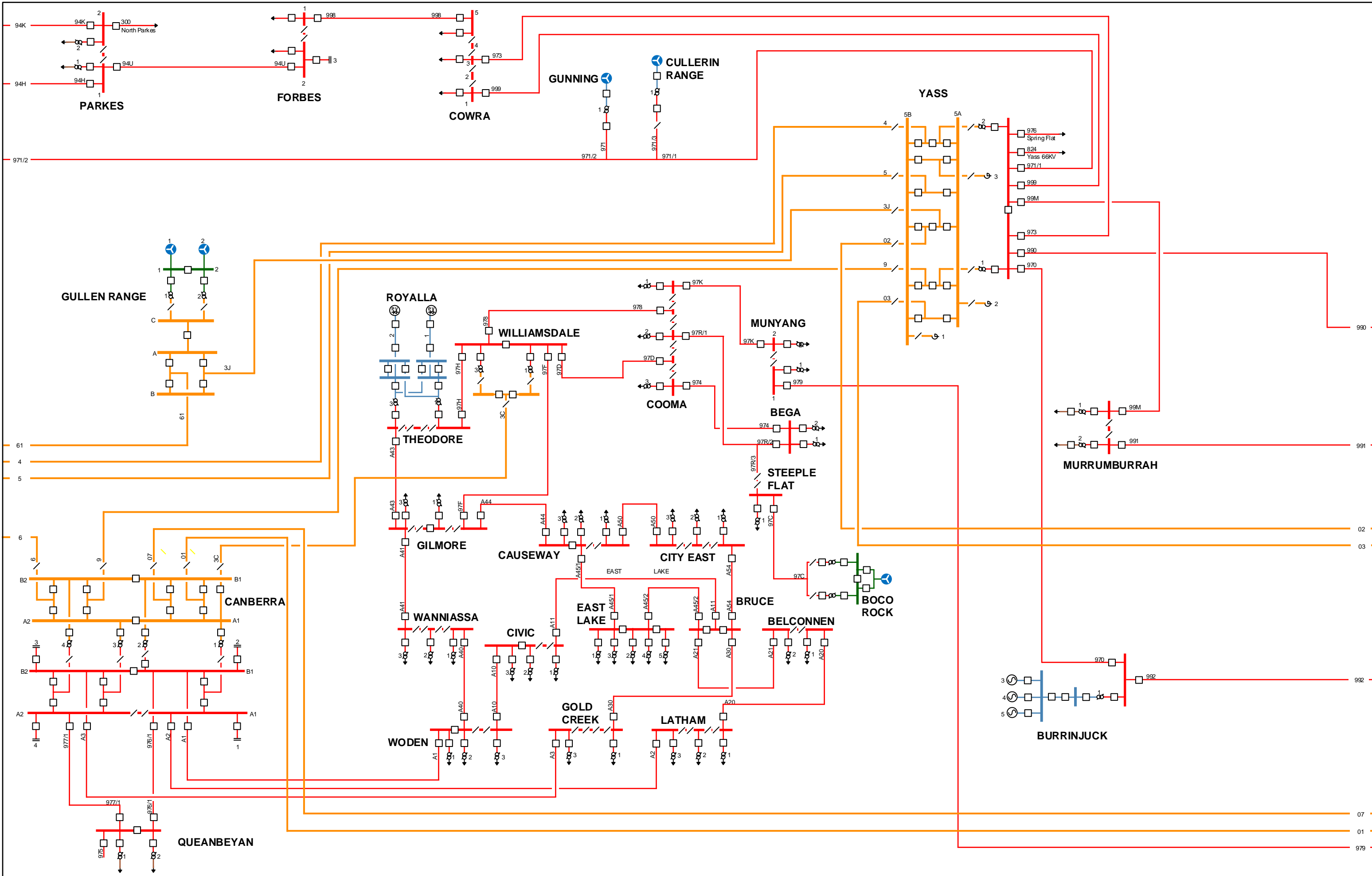

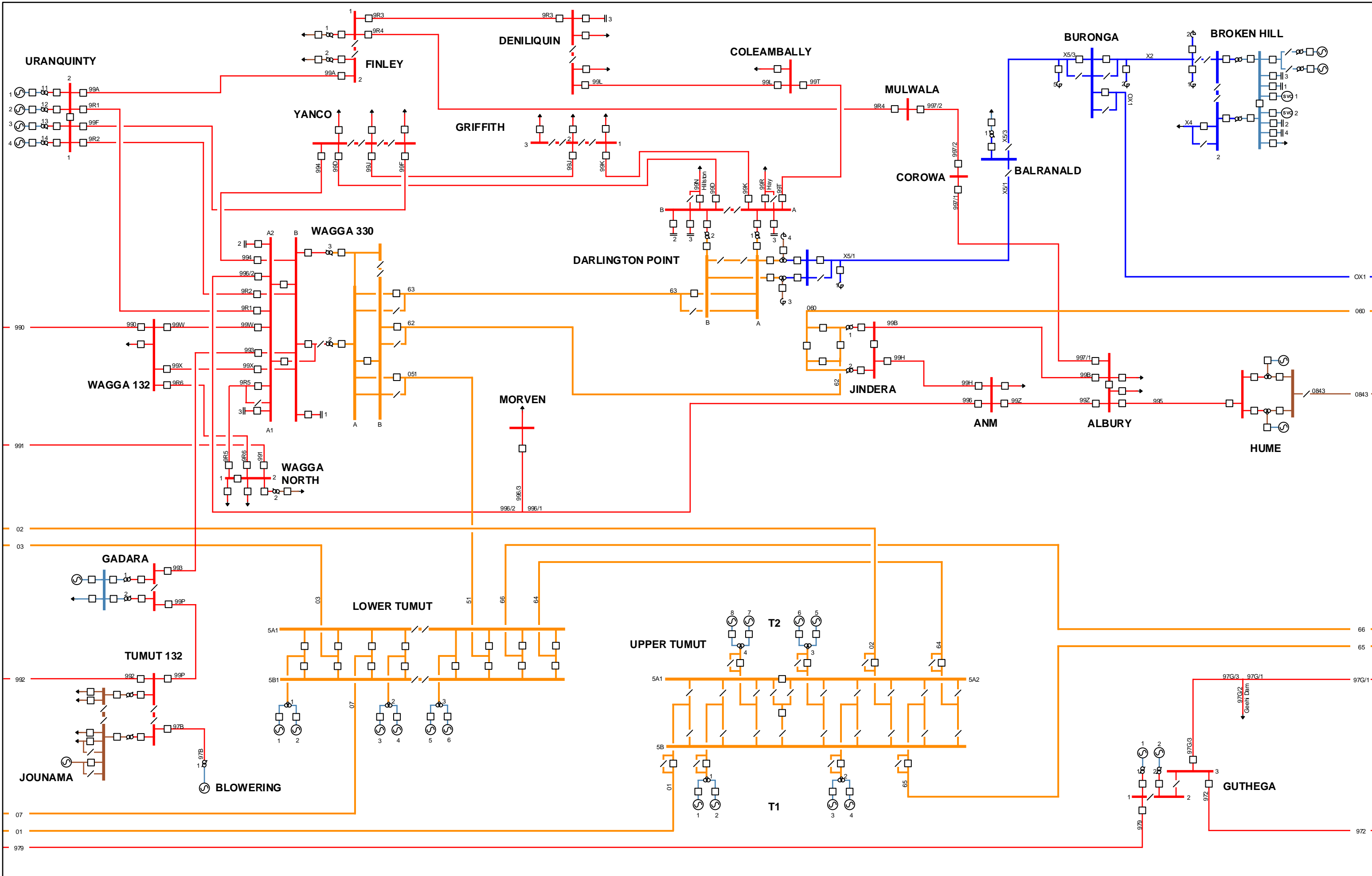



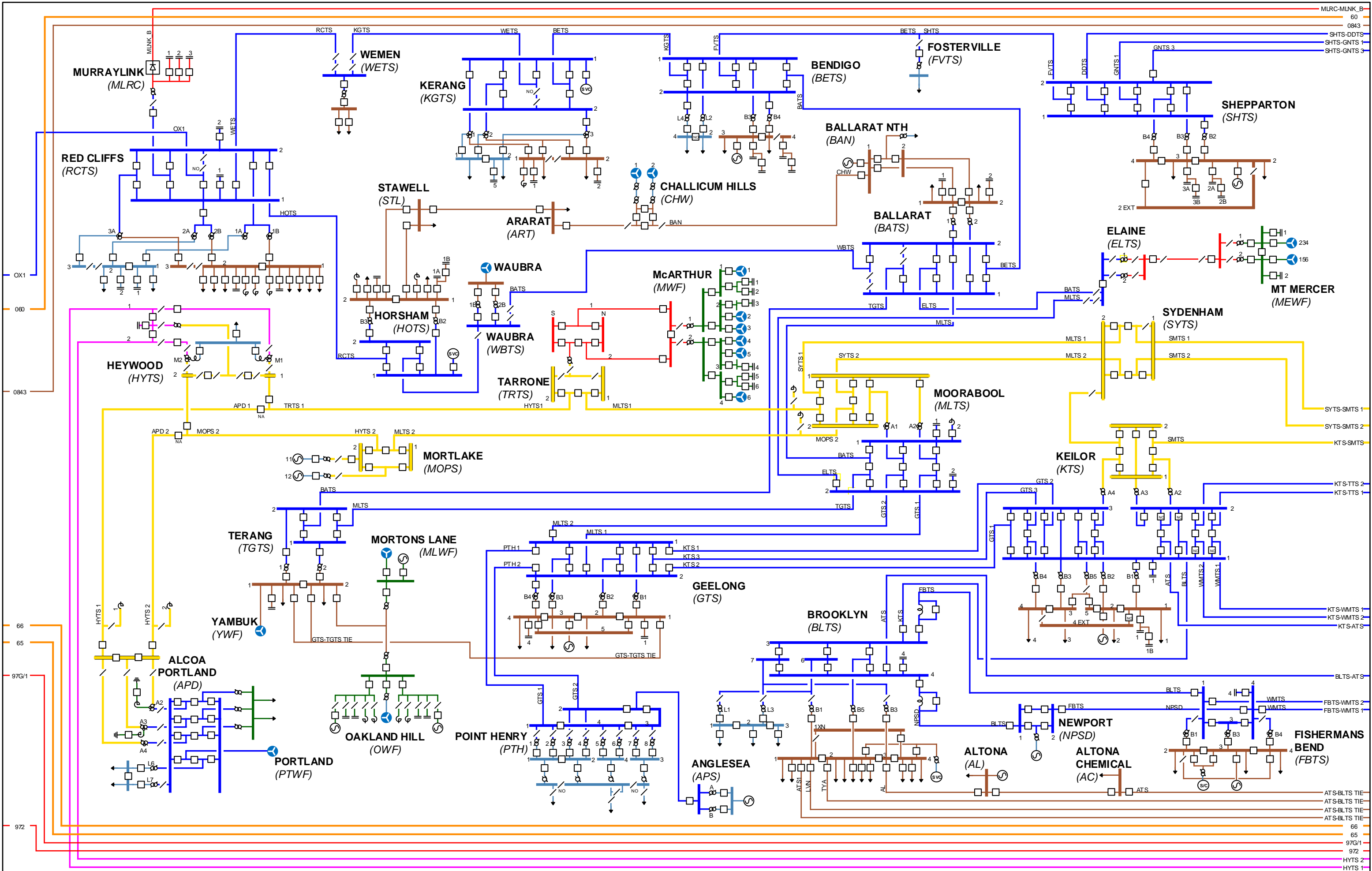



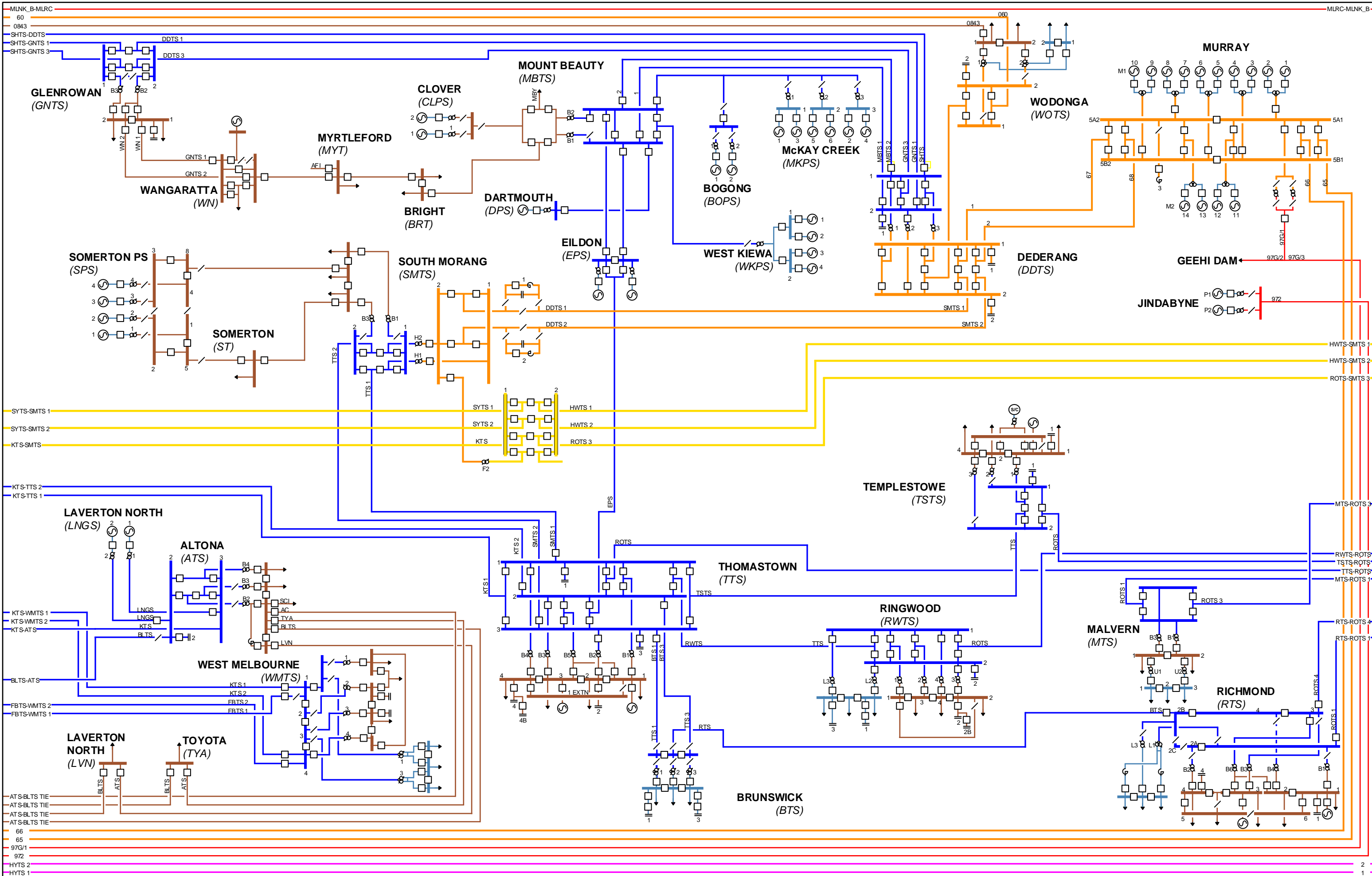

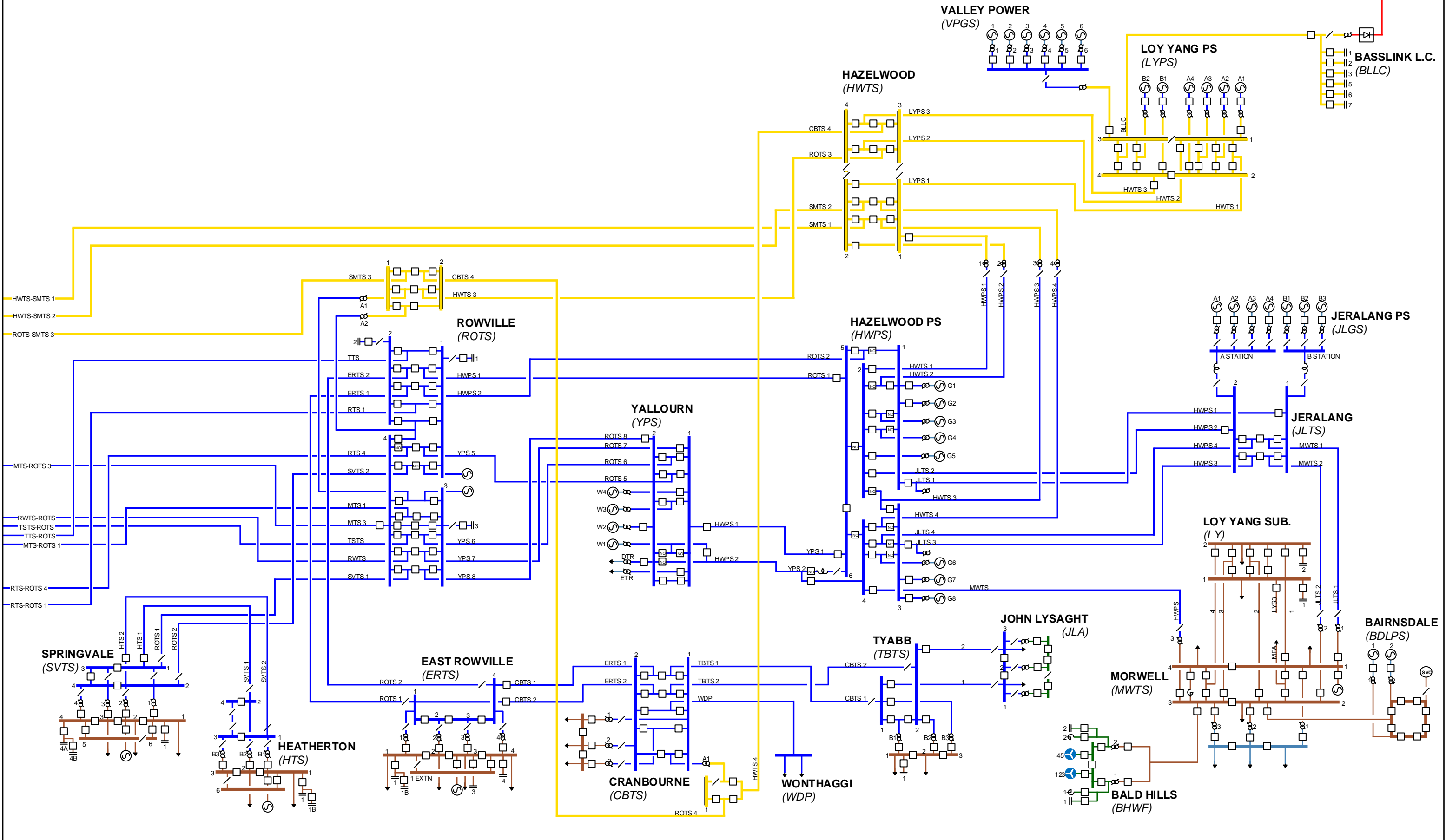

2  
1



**AUSTRALIAN ENERGY MARKET OPERATOR**  
**HIGH VOLTAGE NETWORK**  
**MAIN SYSTEM DIAGRAM**  
**VICTORIA - c**

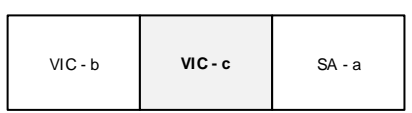

<ul style="list-style-type: none"> <li><span style="color: yellow;">—</span> 500 kV</li> <li><span style="color: orange;">—</span> 330 kV</li> <li><span style="color: pink;">—</span> 275 kV</li> <li><span style="color: blue;">—</span> 220 kV</li> <li><span style="color: red;">—</span> 132 / 110 kV</li> <li><span style="color: green;">—</span> 66 kV</li> <li><span style="color: lightgreen;">—</span> 33 kV</li> <li><span style="color: lightblue;">—</span> 22 kV</li> </ul>	<ul style="list-style-type: none"> <li> Generator</li> <li> Wind Farm</li> <li> Static Var Compensator</li> <li> Synchronous Condenser</li> <li> Circuit breaker</li> <li> Isolator</li> <li> Capacitor Bank</li> <li> Reactor</li> <li> Series Reactor</li> <li> 2 Winding tap transformer</li> <li> 2 Winding fixed tap transformer</li> <li> 3 Winding tap transformer</li> <li> 3 Winding fixed tap transformer</li> <li> Auto transformer</li> </ul>	<p>This diagram is intended to be a high-level representation only, interested parties should always consult with their relevant transmission network service provider (or equivalent) for more accurate information.</p> <p>DATE: 30-01-2015</p>
--	---	---

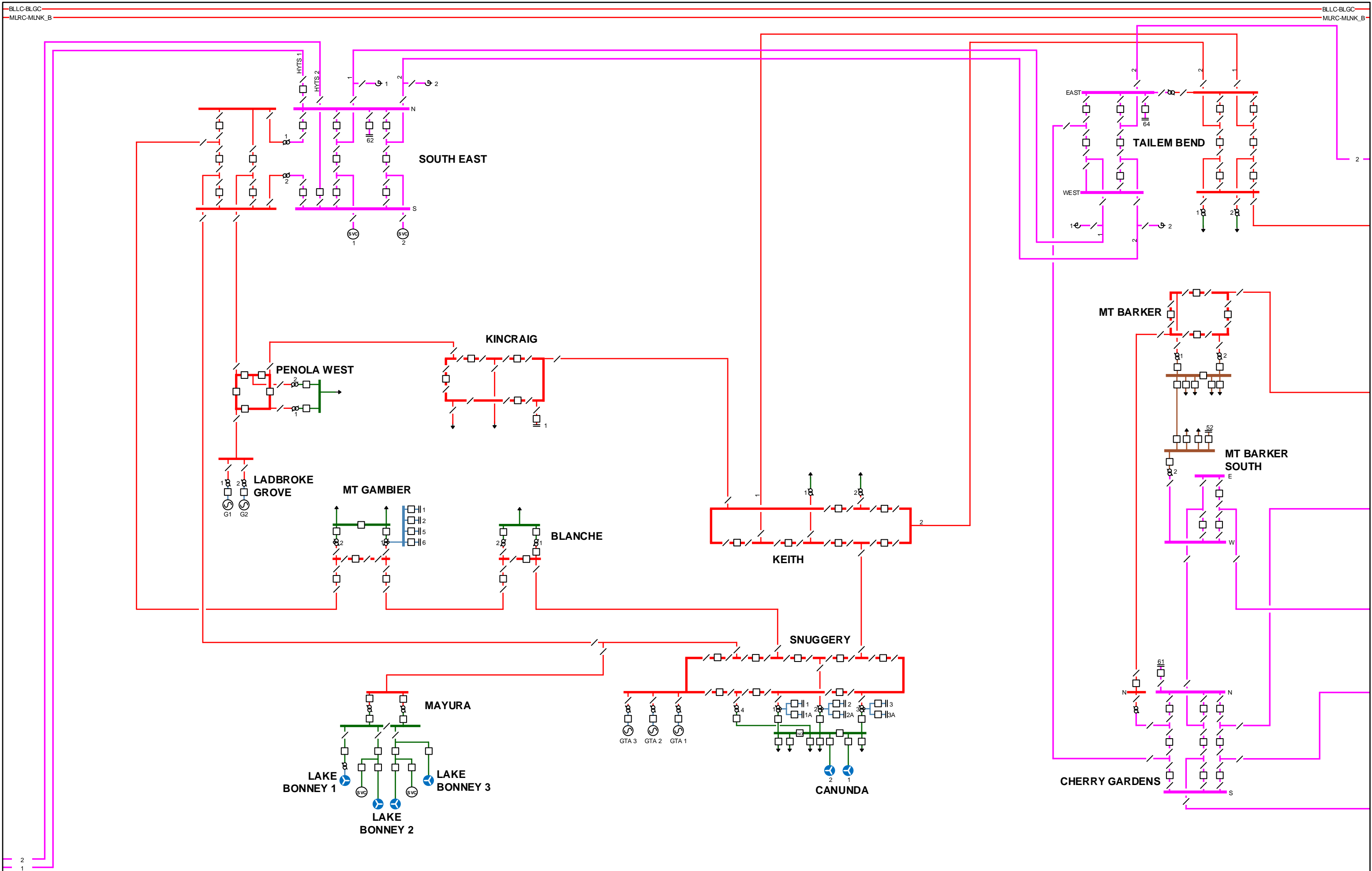

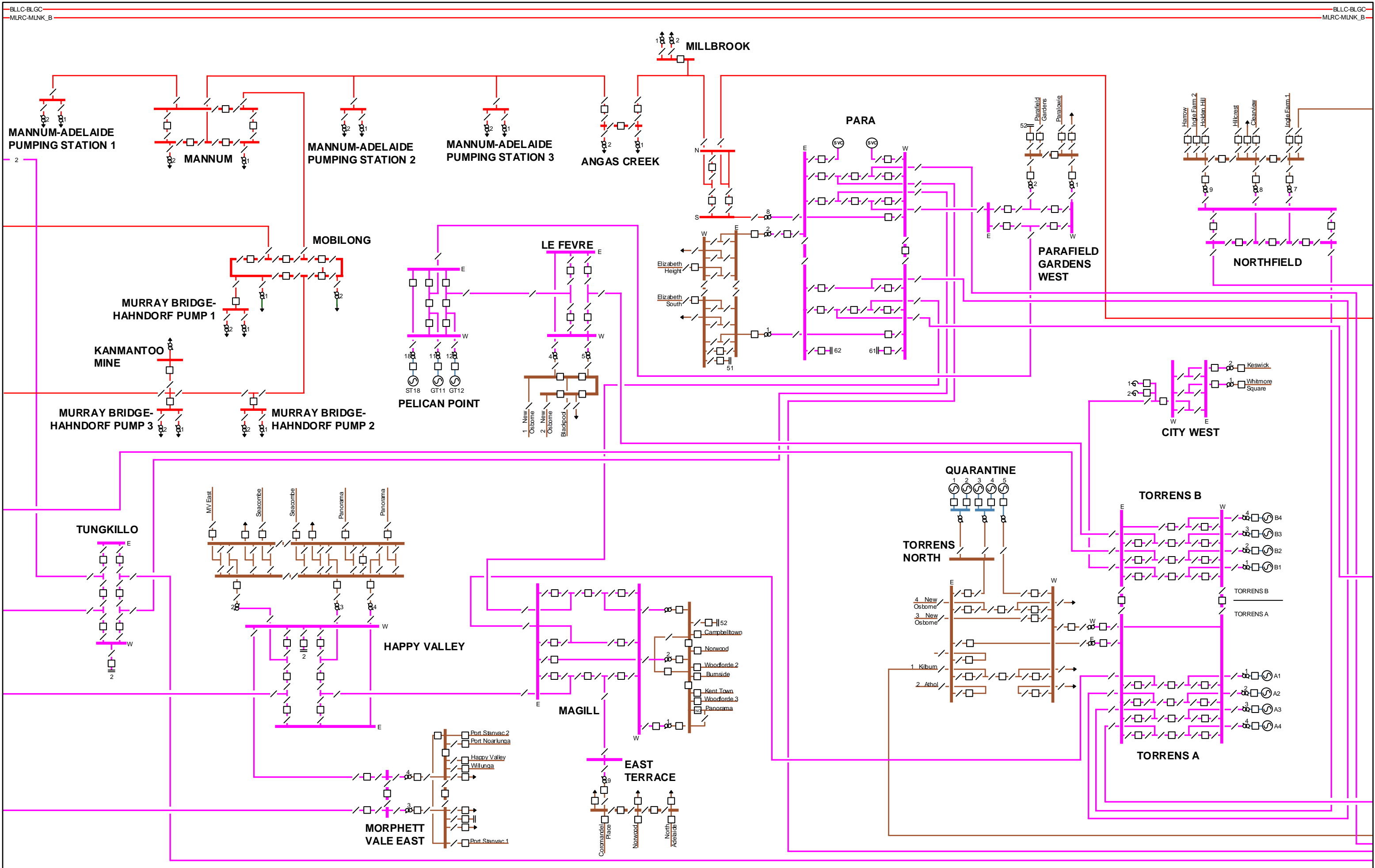

SA - a	SA - b	SA - c
--------	--------	--------

- 500 kV
- 330 kV
- 275 kV
- 220 kV
- 132 / 110 kV
- 66 kV
- 33 kV
- 22 kV

- Generator
- Wind Farm
- Static Var Compensator
- Synchronous Condenser
- Circuit breaker
- Isolator
- Capacitor Bank
- Reactor
- Series Reactor
- 2 Winding tap transformer
- 3 Winding tap transformer
- 2 Winding fixed tap transformer
- 3 Winding fixed tap transformer
- Auto transformer

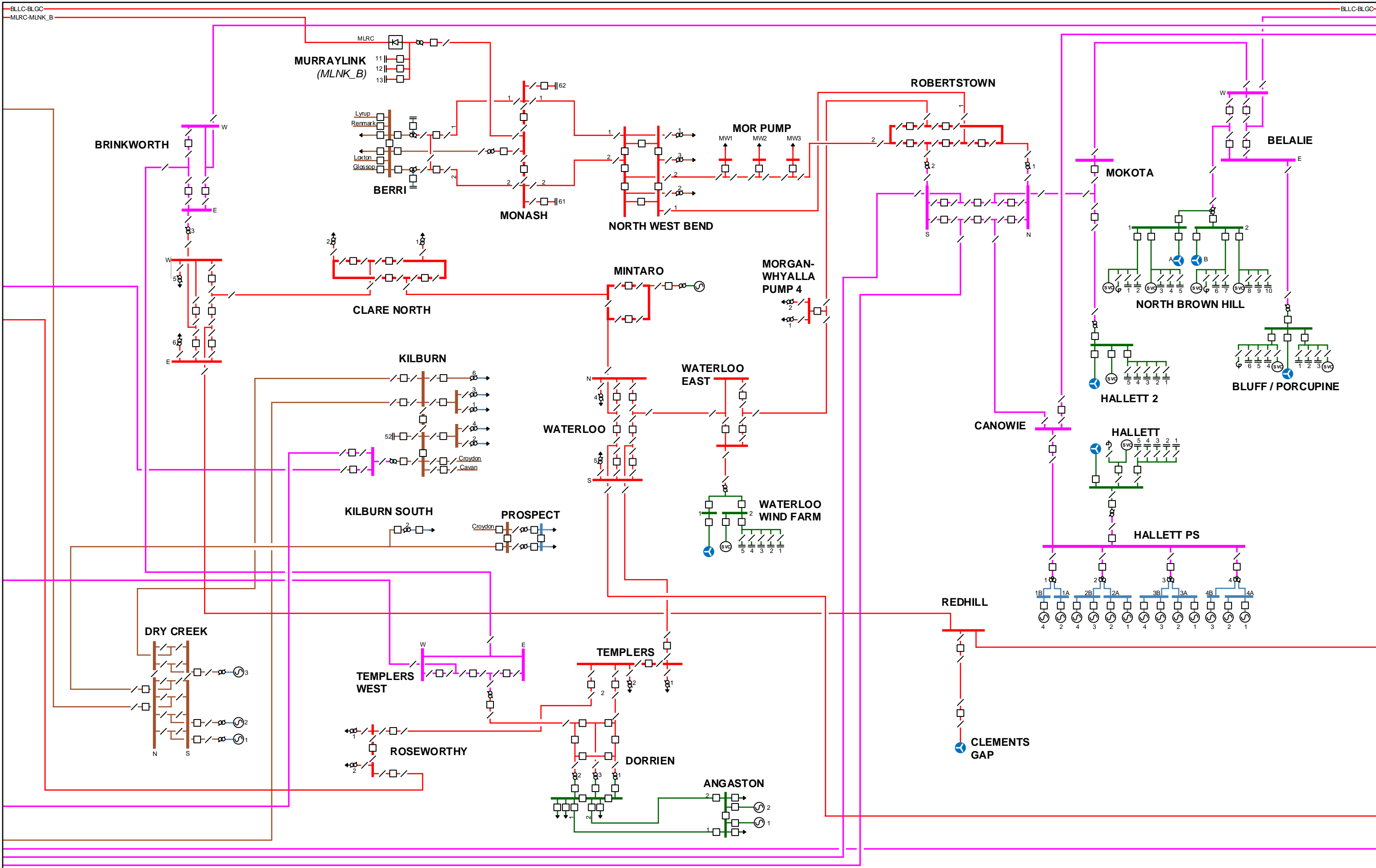

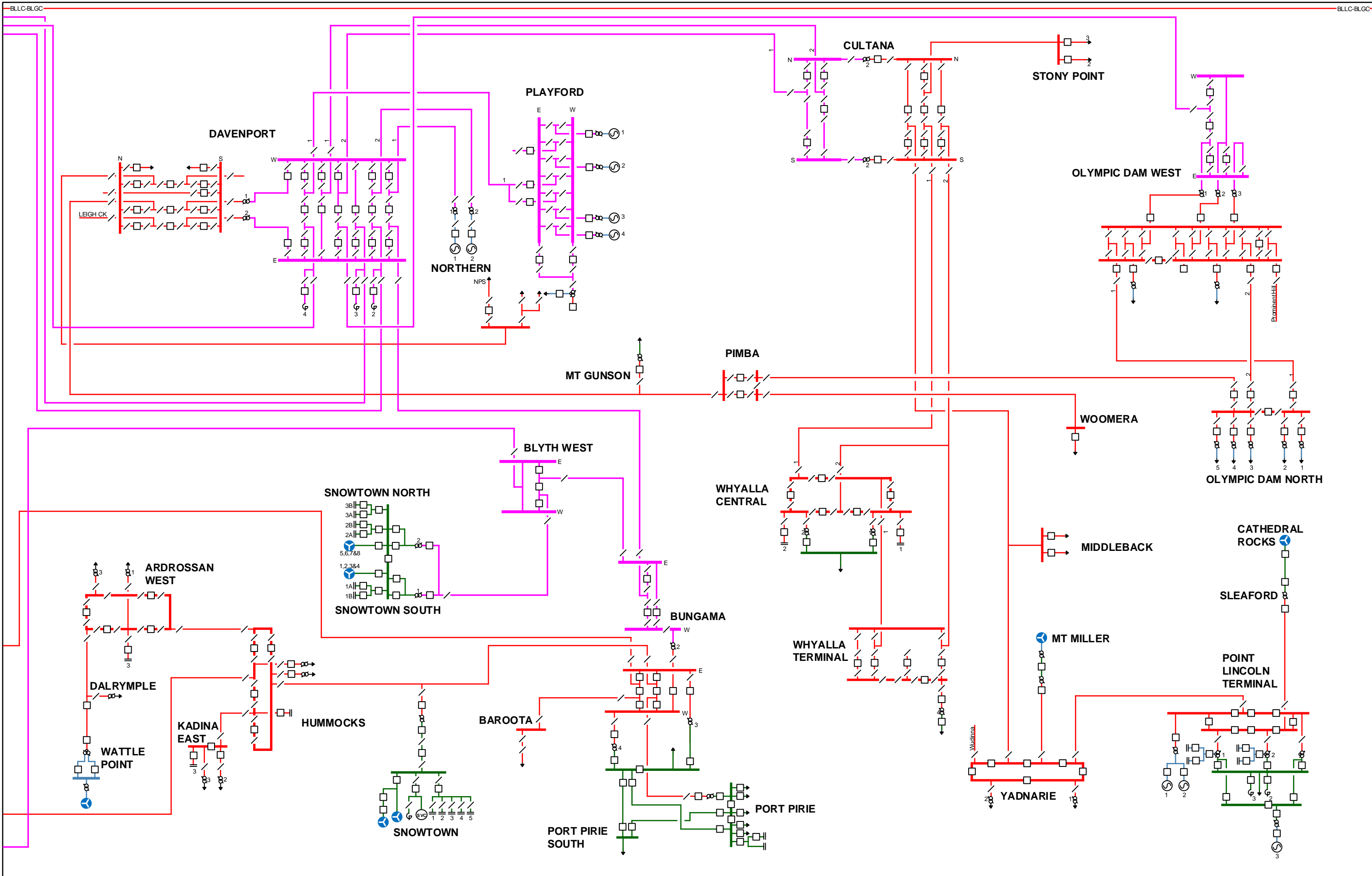

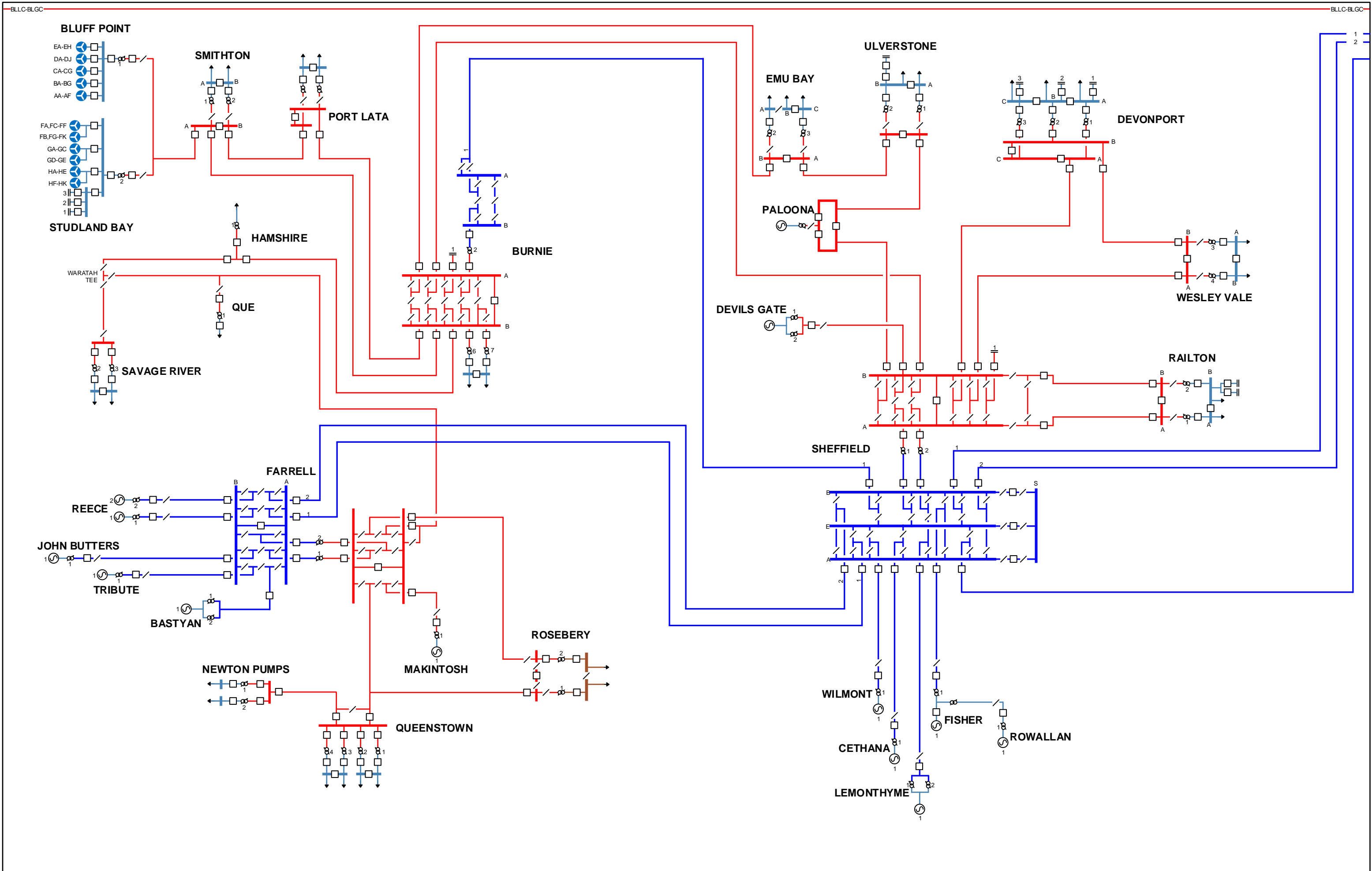



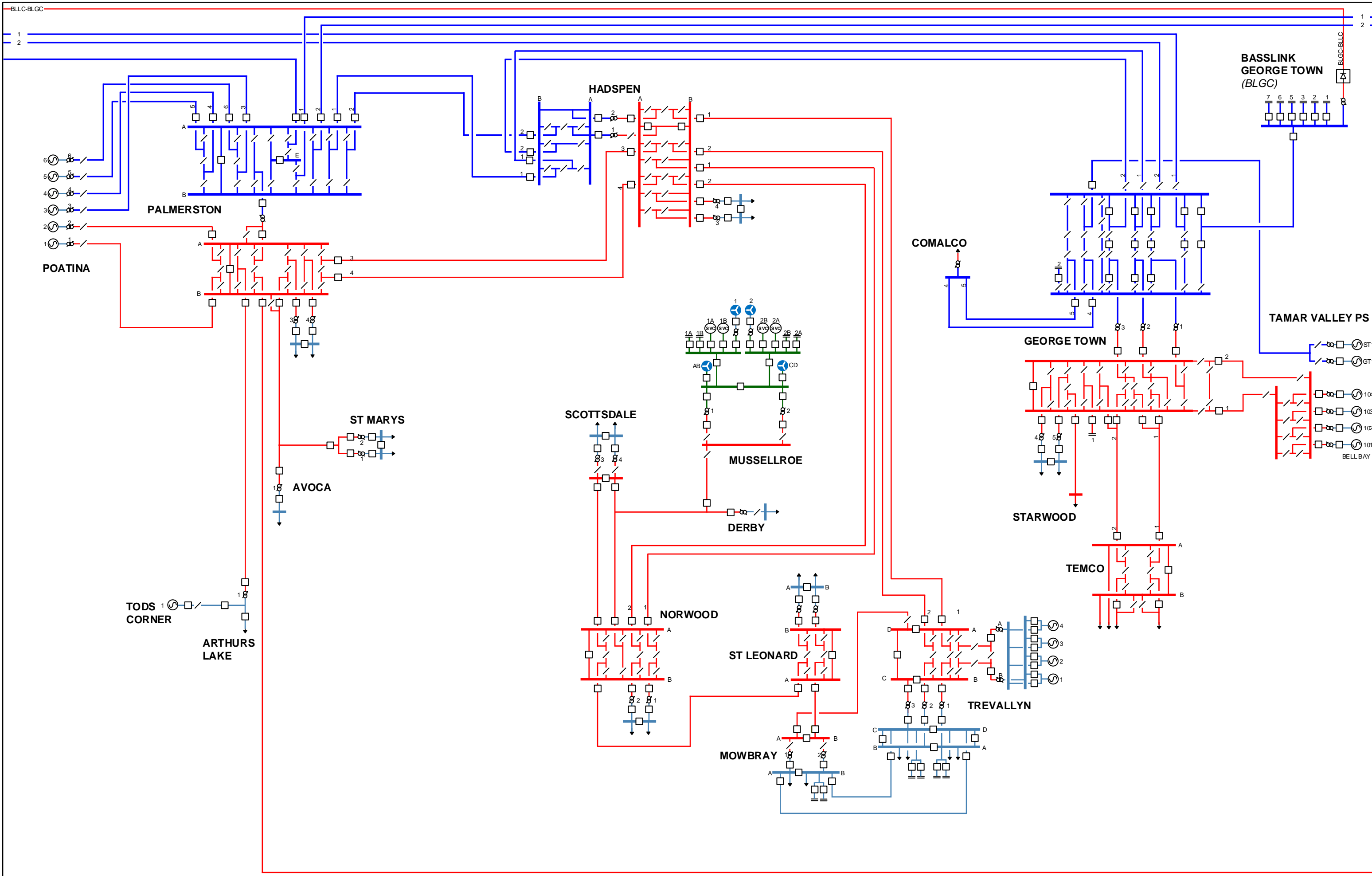

TAS - a	TAS - b	TAS - c
---------	---------	---------

- 500 kV
- 330 kV
- 275 kV
- 220 kV
- 132 / 110 kV
- 66 kV
- 33 kV
- 22 kV

- Generator
- Wind Farm
- Static Var Compensator
- Synchronous Condenser
- Circuit breaker
- Isolator
- Capacitor Bank
- Reactor
- Series Reactor
- 2 Winding tap transformer
- 3 Winding tap transformer
- Auto transformer
- 2 Winding fixed tap transformer
- 3 Winding fixed tap transformer



